

# Vision™ ice and water dispenser

## VU155N Series

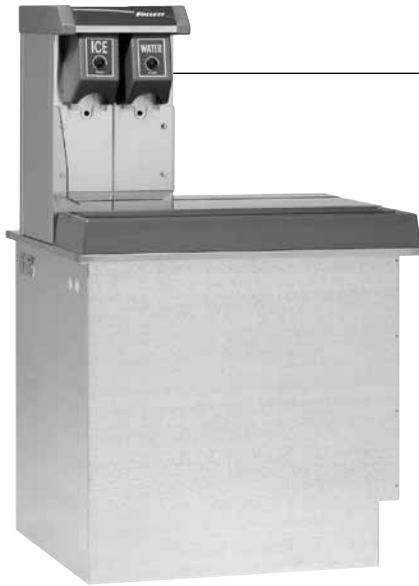

VU155N series		
Ice tower location	Valve type	Item number
left	lever	<b>VU155NOLL</b>
	push-button	<b>VU155NOLP</b>
right	lever	<b>VU155NORL</b>
	push-button	<b>VU155NORP</b>

### Features

150 lb (68.0 kg) undercounter ice storage

Upscale drink station

- low profile with ice storage under the counter
- auto-fill with an ice machine out of view using RIDE® remote ice delivery equipment
- ideal for island configurations
- fits into ADA compliant 34.00" (86.3 cm) counters

Left or right side ice dispense chute

Durable, full stainless exterior

Pre-configured for Follett® RIDE model Chewblet® ice machines

- connect up to two Follett ice machines
- user-preferred, chewable compressed nugget ice
- slow melting, maintains drink temperature
- accepts Chewblet ice or Micro Chewblet ice

Faster, safer manual loading of ice at waist height

- safe, easy waist-height loading front or rear
- eliminates overhead lifting of buckets or loading from ladders
- allows quick reloading during serving period with minimal disruption
- may be manually loaded with cube ice up to 1.00" (2.54 cm) square

Job

Item

## Specification

Ice storage capacity	150 lb (68.0 kg)
<b>W1</b> Width	31.25" (79.4 cm)
<b>W2</b> Width, tower	11.75" (29.8 cm)
<b>D1</b> Depth	27.38" (69.5 cm)
<b>D2</b> Depth, drain pan interior	7.38" (18.74 cm)
<b>D3</b> Depth, tower	16.50" (41.9 cm)
<b>H1</b> Height, upper section	22.00" (55.9 cm)
<b>H2</b> Height, lower section	27.88" (70.8 cm)
<b>H3</b> Height, leg	adjustable 6.00 - 9.00" (15.24 - 22.86 cm)
<b>H4</b> Ice dispense height clearance	10.00" (25.4 cm)
<b>K1</b> Ice dispense chute	utility connections are on opposite side as ice dispense chute
<b>L1</b> Countertop to lever	8.25" (20.96 cm)
<b>L2</b> Front of dispenser to lever	7.50" (19.05 cm)
Installation clearance	51.00" (129.5 cm) above counter for drop-in installation, 1.25" (3.18 cm) maximum counter thickness
Service clearance	12.00" (30.5 cm) minimum on side opposite of ice chute, 36.00" (91.4 cm) minimum above counter for auger removal
NOTE: For additional information refer to form# 3105.	
<b>C1</b> Electrical	2.4 amps. 8' (2.4 m) cord and NEMA 5-15 90° plug provided with each dispenser. Separate circuits and disconnects required for each dispenser.
115 V/60/1	
<b>C2</b> Drain - ice storage	3/4" PVC slip joint
<b>C3</b> water inlet	3/8" tubing
<b>C4</b> Drain - drain pan	3/4" PVC hose
<b>C5</b> Ice machine electrical connection	Pre-wired bin signal junction box with twist lock connector(s). Standard length is 20' (6.1 m).
<b>C6</b> Ice machine ice transport tube connection	two ice transport tube entry holes on each side
<b>C7</b> Air Break	do not connect to drain system
Temperature range	60 - 90 F (16 - 32 C)
Approximate shipping weight	250 lb (113.4 kg)
NOTE: For indoor use only	

### Short form specification:

Ice and water dispenser to be Follett model \_\_\_\_\_. Dispenser to store up to 150 lb (68.0 kg) of ice and allow loading of ice at waist level from front or rear. Ice and water tower and top to be of stainless steel with plastic trim. Full-length drain pan to be one-piece molded polyethylene. To include 6.00 - 9.00" (15.24 - 22.86 cm) adjustable legs for dispenser support. Storage area to be polyethylene, insulated with non-CFC foam polyurethane. Dispenser to be pre-configured to accept up to two RIDE model ice machines, sold separately. 8' (2.4 m) cord and NEMA 5-15 90° hospital grade plug provided. Dispenser to be NSF, UL, and cUL listed.

## Dimensional drawing

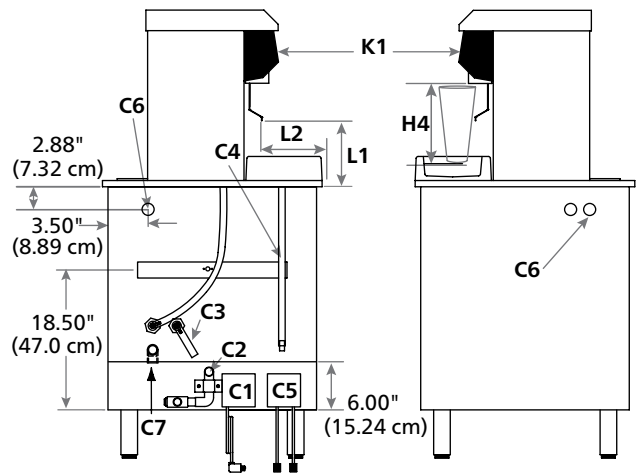
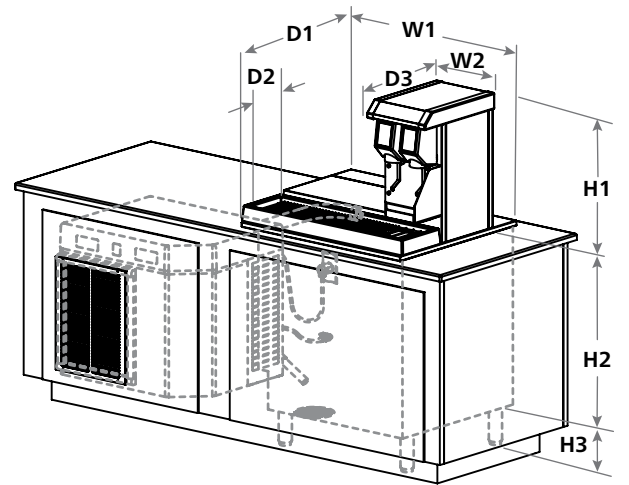

## Counter cutout detail

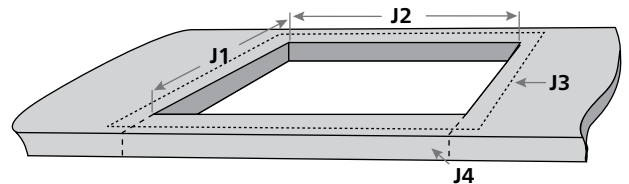

<b>J1</b> Cutout depth	26.25" (66.68 cm) ± .0125" (.0317 cm)
<b>J2</b> Cutout width	30.375" (77.152 cm) ± .0125" (.0317 cm)
<b>J3</b> Flat surface required	31.25" (79.375 cm) W x 28.00" (71.12 cm) D
<b>J4</b> Optional – counter front may be removed for slide-in installation	

Vision is a trademark of Follett Corporation.

Chewblet, Follett and RIDE are registered trademarks of Follett Corporation, registered in the US. Follett reserves the right to change specifications at any time without obligation. Certifications may vary depending on country of origin.

## VU155N series