

# CM550 SERVICE PARTS

This section contains the parts illustrations and parts lists for the CM550.

A "no number" designation, when found in the part number column, indicates the part in question is not available from Scotsman as an assembly. This designation is used only for clarity in making the list.

When ordering parts, to avoid costly delays and errors, give the part number, the complete description as shown in the list, and the quantity of each part or assembly required.

## TABLE OF CONTENTS

Exterior Panels.....	2
Interior Panels.....	3
Air Cooled Refrigeration.....	4
Water System .....	5
Control Box .....	6
Wiring Diagrams .....	7

# CM550 SERVICE PARTS

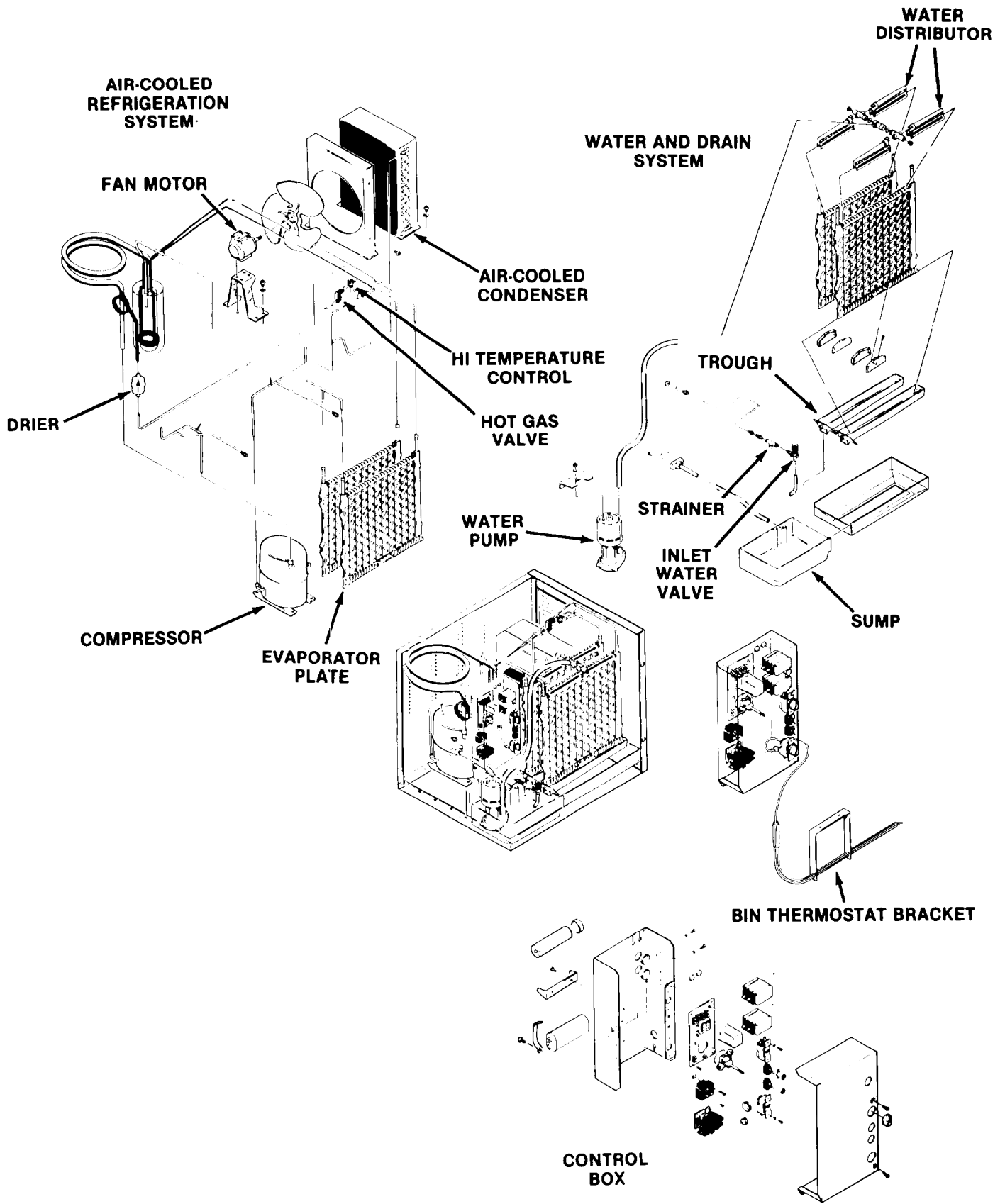

# CM550 SERVICE PARTS

## CABINET ASSEMBLY

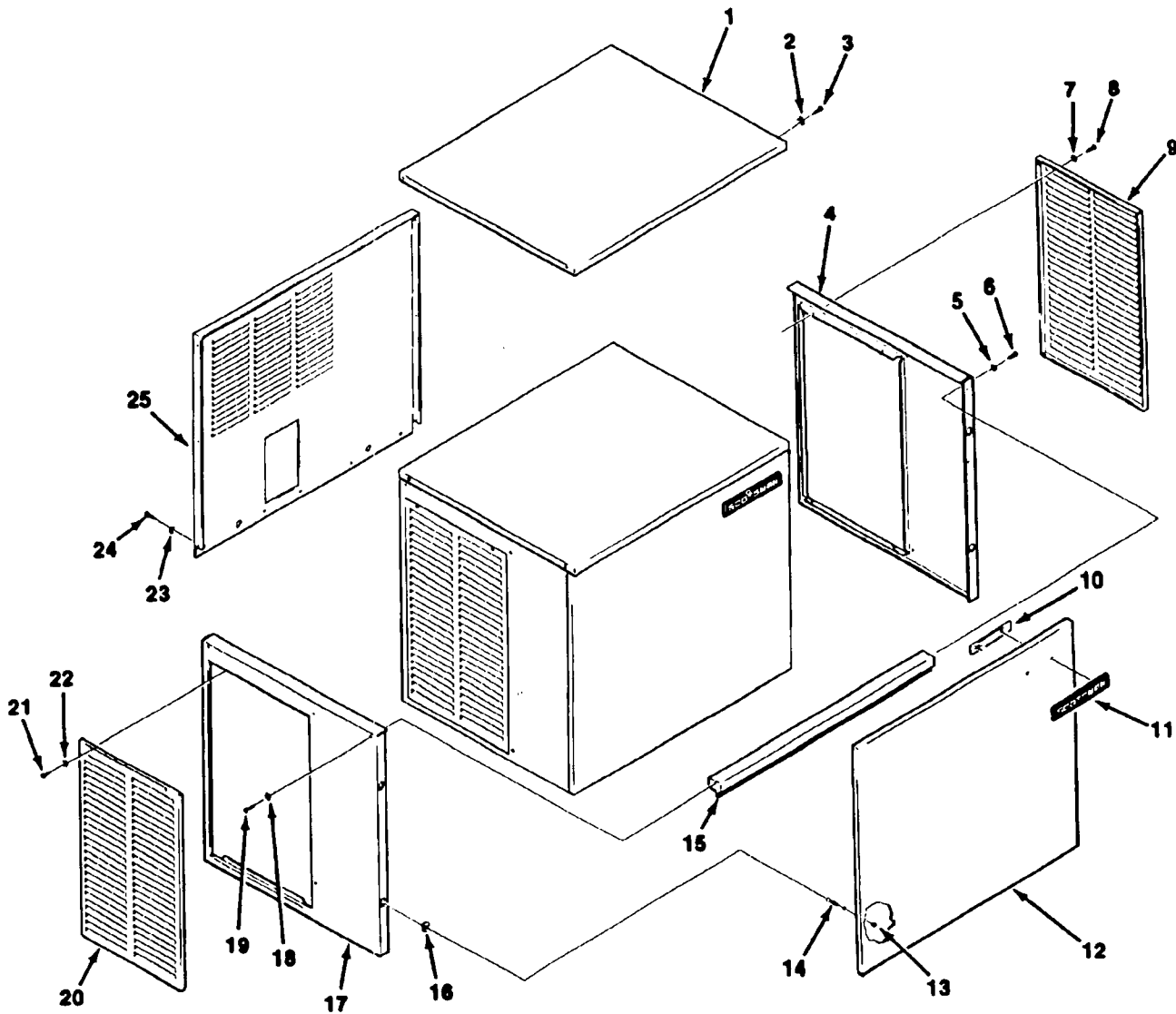

ITEM NUMBER	PART NUMBER	DESCRIPTION	ITEM NUMBER	PART NUMBER	DESCRIPTION
1	A32159-001	Top Panel, Painted	13	03-1406-04	Nut
	A32159-002	Top Panel, S. S.	14	15-0411-00	Strike
2	03-1417-03	Lockwasher	15	A32169-001	Front Support
3	03-1531-01	Screw	16	02-0836-00	Cabinet Catch
4	A32162-001	Right End Panel, Paint	17	A32163-001	Left End Panel, Paint
	A32162-002	Right End Panel, S.S.		A32163-002	Left End Panel, S.S.
5.	03-1417-03	Lockwasher	18	03-1417-03	Lockwasher
6	03-1531-01	Screw	19	03-1531-01	Screw
7	03-1417-03	Lockwasher	20	A32161-001	Service Panel, Paint
8	03-1404-12	Screw		A32161-002	Service Panel, S.S.
9	A32161-001	Service Panel, Painted	21	03-1404-12	Screw
	A32161-002	Service Panel, S.S.	22	03-1412-03	Lockwasher
10	03-0271-00	Speed Nut	23	03-1417-03	Lockwasher
11	15-0711-00	Emblem	24	03-1531-01	Screw
12	A32160-001	Front Panel, Painted	25	A32202-001	Back Panel
	A32160-002	Front Panel, S.S.			

# CM550 SERVICE PARTS

## CABINET INTERIOR

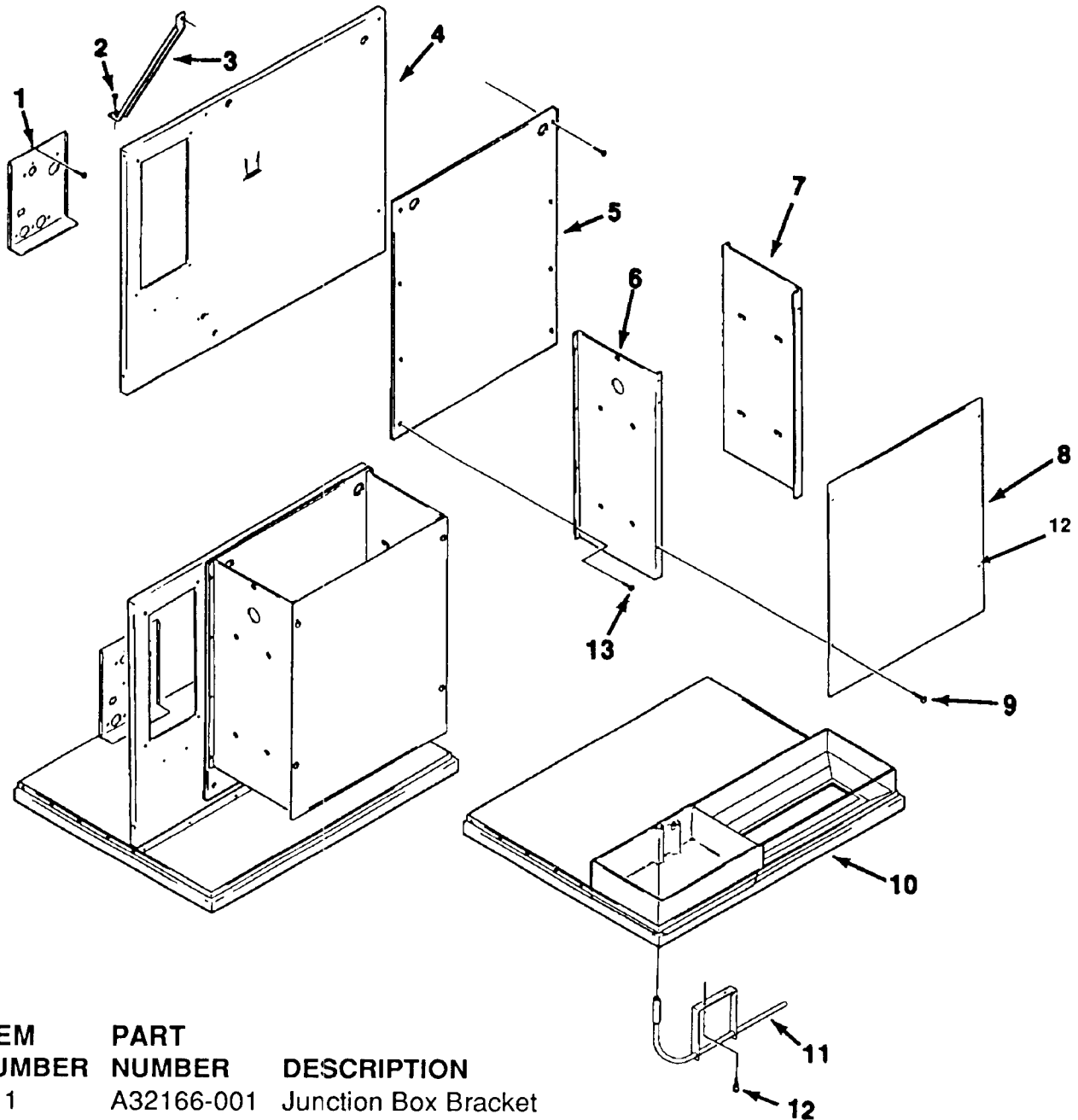

ITEM NUMBER	PART NUMBER	DESCRIPTION
1	A32166-001	Junction Box Bracket
2	03-1645-01	Screw
3	A32210-001	Support Brace
4	A32158-001	Retainer
5	02-2867-01	Splash Panel
6	A32172-001	Evaporator Bracket, Right
7	A32173-001	Evaporator Bracket, Left
8	A32165-001	Evaporator Plate Cover
9	03-0727-09	Thumbscrew
10	A32153-001	Base, with sump and chute
11	A32262-001	Bin Thermostat Bracket
12	03-0727-09	Thumbscrew
13	03-1531-02	Screw

# CM550 SERVICE PARTS

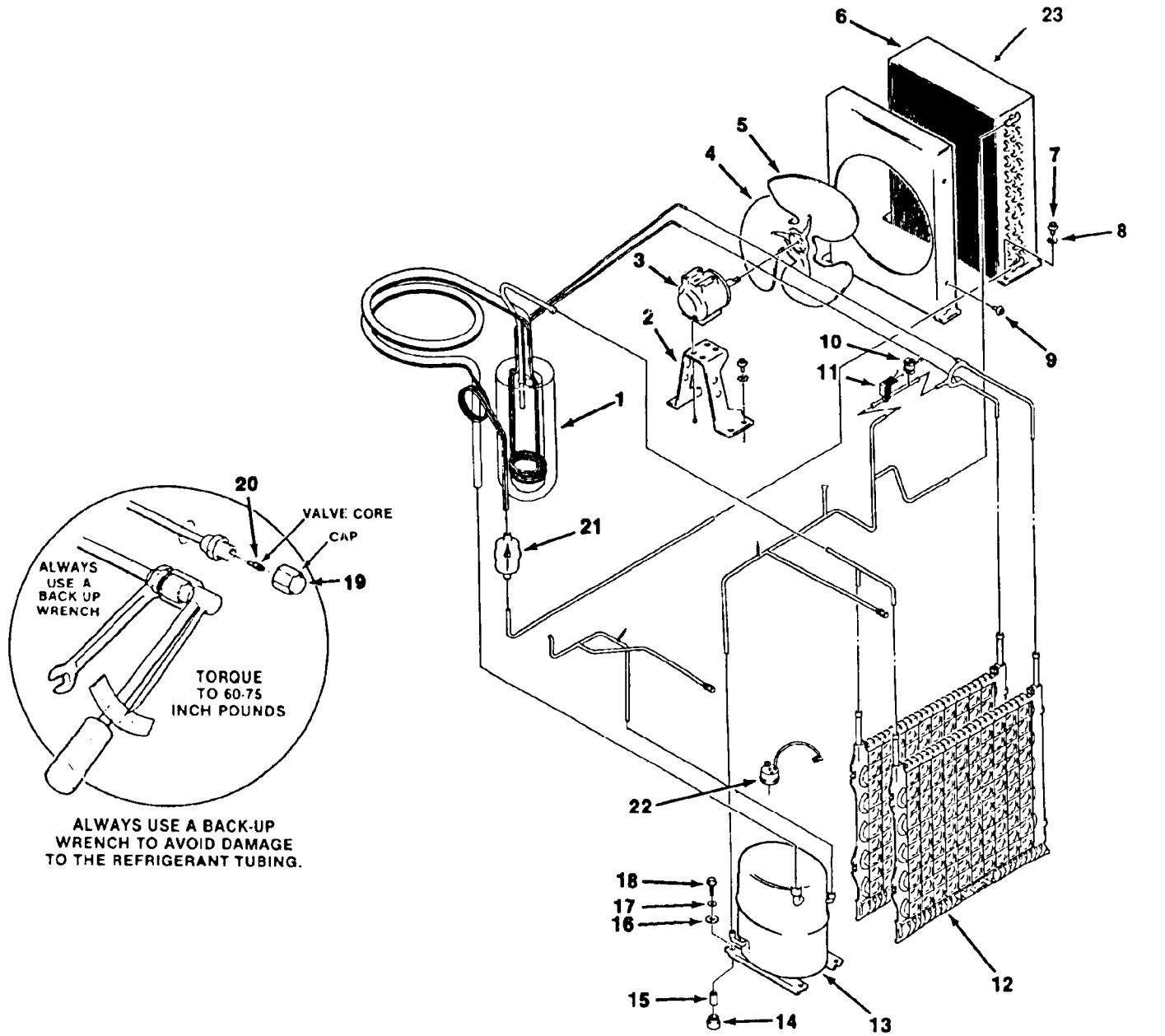

ITEM NUMBER	PART NUMBER	DESCRIPTION	ITEM NUMBER	PART NUMBER	DESCRIPTION
1	A32174-020	Heat Exchanger	11	12-2135-01	Hot Gas Valve
2	18-3739-01	Fan Motor Bracket	12	A30296-020	Evaporator
3	18-5105-11	Fan Motor	13	18-6100-01	Compressor
4	18-3732-01	Fan Blade	14	18-2200-28	Grommet
5	A32170-001	Fan Shroud	15	18-2200-27	Sleeve
6	18-3709-01	Condenser	16	03-1407-07	Washer
7	03-1645-01	Screw	17	no number	washer
8	03-1410-03	Lockwasher	18	03-1405-20	Screw
	03-1407-05	Washer	19	16-0563-00	Cap
9	03-1531-01	Screw	20	16-0560-00	Core
10	12-2300-03	Hi Temp Cut Out	21	02-2426-02	Drier
			22	18-6100-50	Compressor Overload
			23	A32975-001	Foam Filter

# CM550 SERVICE PARTS

## WATER SYSTEM

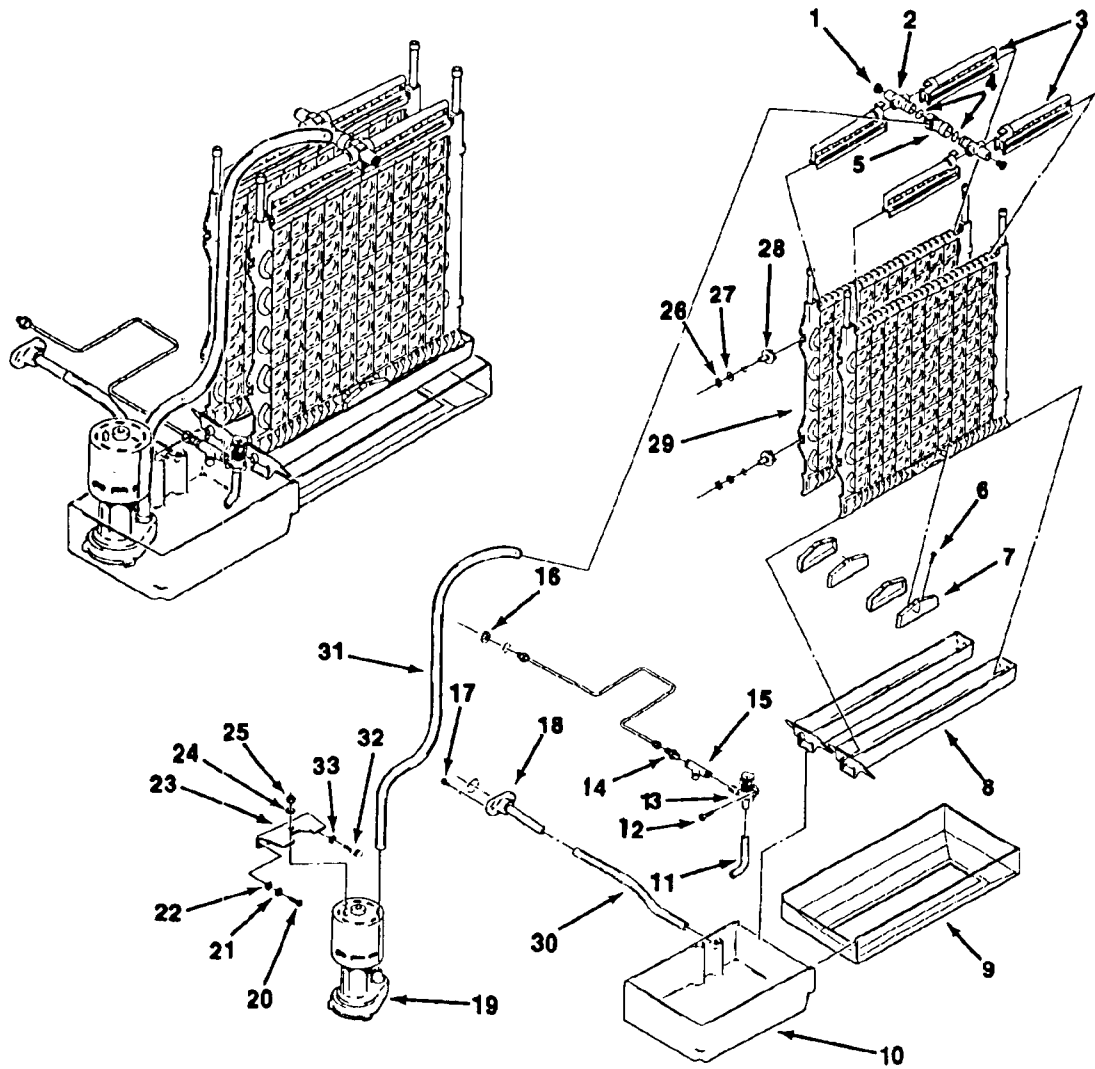

ITEM NUMBER	PART NUMBER	DESCRIPTION	ITEM NUMBER	PART NUMBER	DESCRIPTION
1	13-0840-01	Manifold Plug	18	A32282-003	Drain Ass. (Air Cooled)
2	A29703-001	Manifold Water Tube	19	12-2265-21	Water Pump Assembly
3	02-2527-01	Water Distrib. Tube	20	03-1403-17	Screw
4	13-0617-48	O-Ring (2)	21	03-1407-03	Washer
5	02-2519-01	Plastic Tee	22	03-1408-31	Washer
6	03-1404-10	Screw	23	A30914-002	Pump Mounting Bracket
7	02-2878-01	Sump End Cover	24	03-1417-05	Lockwasher
8	02-2868-01	Drain Trough	25	03-1406-05	Nut
9	no number	Cube Chute	26	03-1394-03	Pal Nut
10	02-2869-01	Sump	27	03-1408-34	Special Washer
11	A30918-001	Sump Inlet Tube	28	02-2642-01	Plate Mount
12	03-1531-01	Screw	29	A30296-020	Evaporator
13	12-2313-04	Solenoid Valve	30	13-0674-07	Drain Hose, 8"
14	16-0791-01	Half Union	31	13-0674-07	Pump Hose, 33"
15	16-0162-00	Stainer	32	03-0727-09	Thumbscrew
16	03-1394-01	Pal Nut	33	03-1417-03	Lockwasher
17	03-1645-01	Screw			

# CM550 SERVICE PARTS

## CONTROL BOX

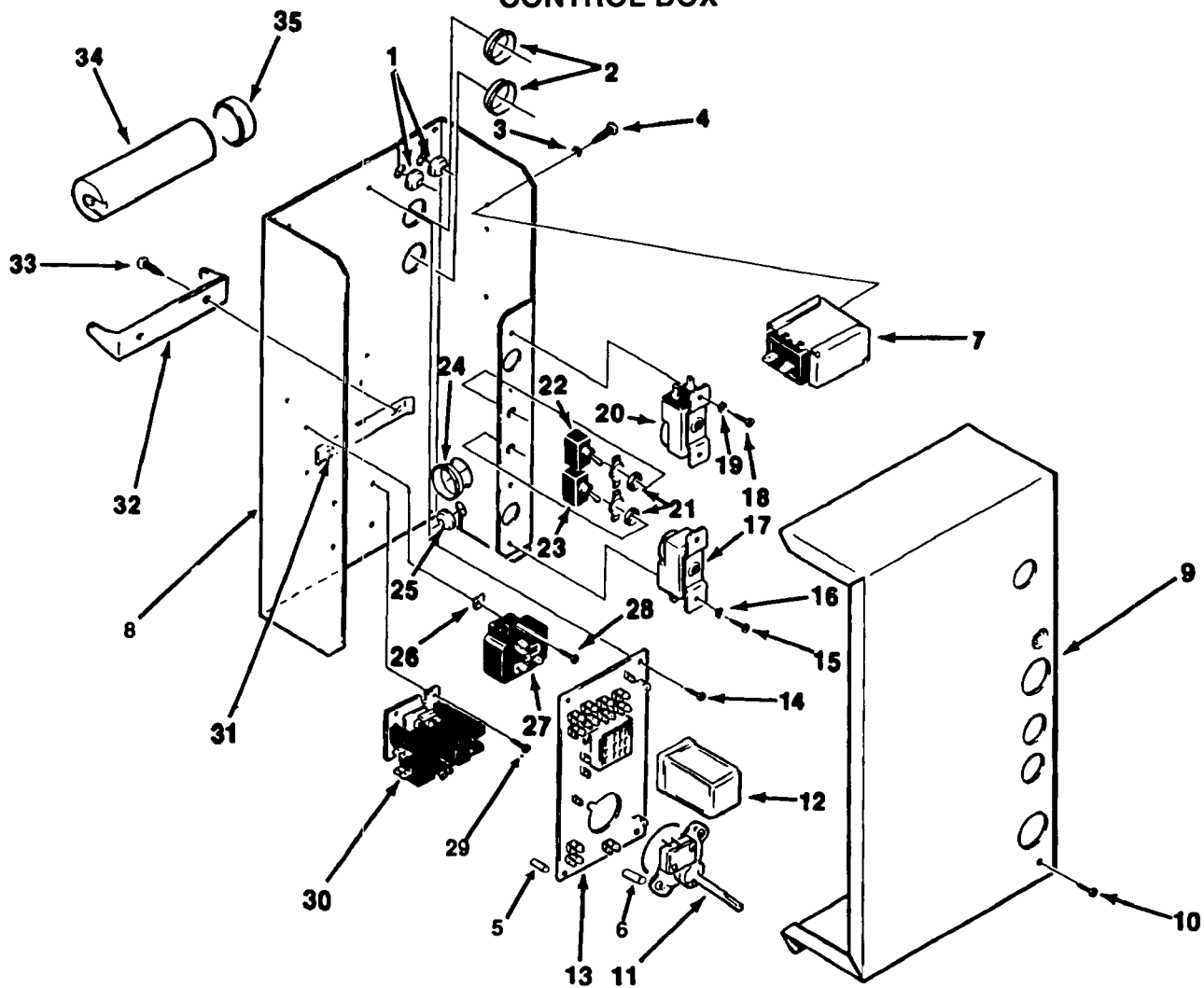

ITEM NUMBER	PART NUMBER	DESCRIPTION	ITEM NUMBER	PART NUMBER	DESCRIPTION
1	13-0557-00	Grommet	17	11-0427-02	Bin Thermostat
2	12-1213-10	Snap Bushing	18	03-1403-05	Screw
3	03-1417-18	Lockwasher	19	03-1417-03	Lockwasher
4	03-1403-02	Screw	20	11-0435-01	Cube Size Control
5	02-2242-02	Stand Off	21	03-1417-16	Lockwasher
6	02-2242-01	Stand Off	22	12-0426-01	Switch
7	11-0425-01	High Pressure Switch (Air Cooled)	23	12-0426-01	Switch
8	no number	Control Box	24	12-1213-17	Snap Bushing
9	A32168-001	Control Box Cover	25	13-0557-00	Grommet
10	03-1531-01	Screw	26	03-1423-01	Speed Nut
11	12-1980-01	Timer & Switch	27	18-1903-44	Potential Relay
12	12-1879-02	Relay, 115 V	28	03-1403-02	Screw
13	12-1912-01	Circuit Board	29	03-1403-15	Screw
14	03-1403-02	Screw	30	12-2048-01	Contactor
15	03-1403-05	Screw	31	03-1103-00	Twin Speed Nut
16	03-1417-03	Lockwasher	32	18-2200-39	Start Capacitor Bracket
			33	03-1403-15	Screw
			34	18-1901-42	Start Capacitor

# CM550 WIRING DIAGRAMS

**A34383-001**

Caution: More than one disconnect means may be required to disconnect all power to this unit.

USE COPPER CONDUCTORS ONLY

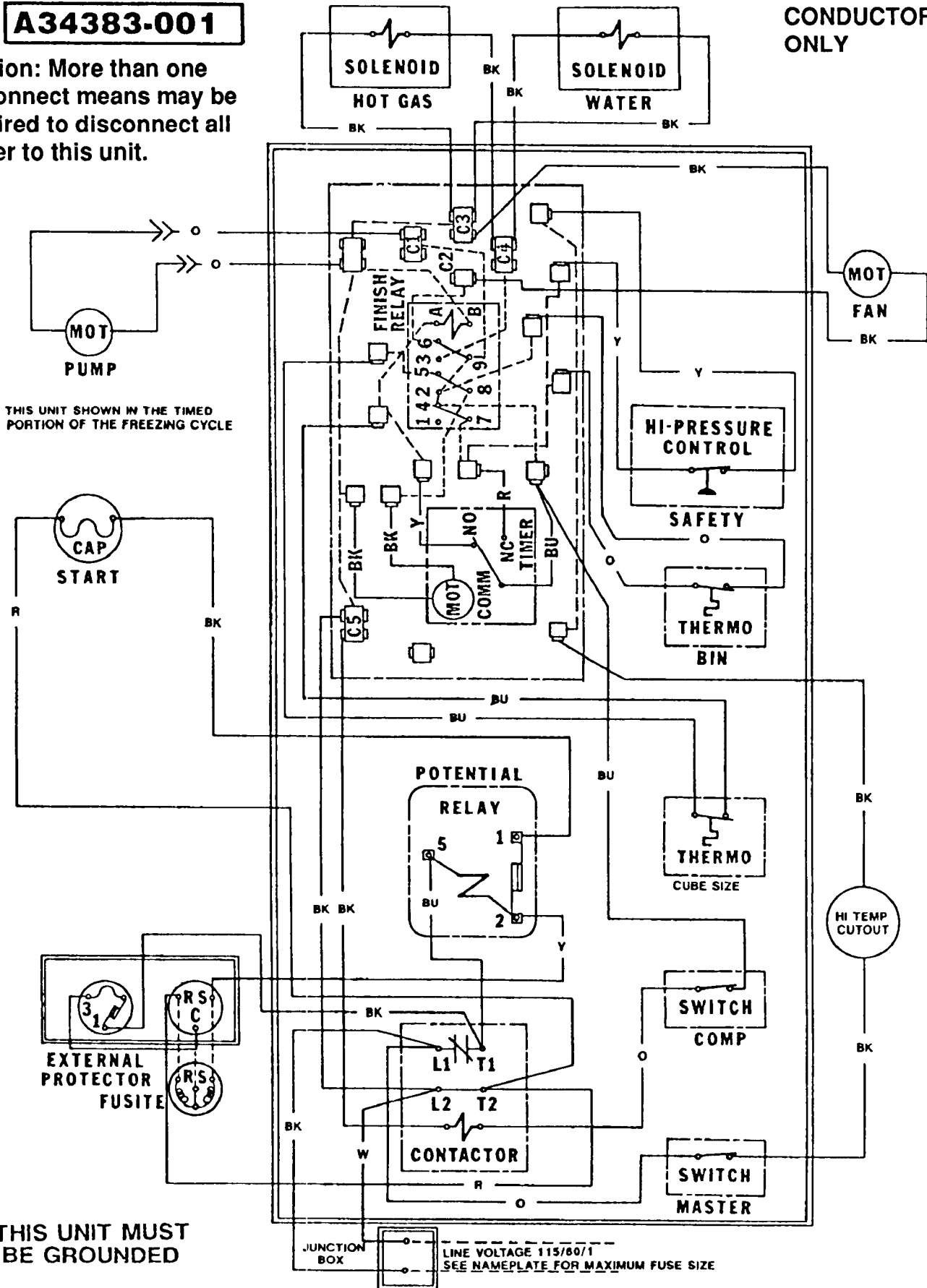

THIS UNIT MUST BE GROUNDED

Component Layout Diagram for CM550AE-1A (115/60/1)

June, 1988

Page 7



# CM550 WIRING DIAGRAMS

Schematic Diagram for CM550AE-1A (115/60/1)

