

TABLE OF CONTENTS
F5-2 SECTION

	Page
FORWARD	
WARRANTY	
GENERAL	
Specifications.....	1
SPECIFICATIONS	
Dimensions SF-2F.....	2
Dimensions SF-2WSF.....	3
Capacity.....	4
INSTALLATION	
Uncrating.....	5
Location.....	6
Erection, Stands, Chutes.....	7
Plumbing.....	8
Electrical.....	8
Instructions.....	9
SERVICE	
Starting Machine.....	10
Refrigerant Charge.....	11
Water Level.....	11
Electrical System.....	12
Controls.....	12-13
Refrigeration Cycle.....	14
Water Cycle.....	15
Cabinet Water Schematic.....	16
Chassis.....	17
Freezer Assembly.....	18-19
Wiring Diagrams.....	20-21
Service Analysis Chart.....	22-24
Winsmith Gear Reducer.....	25
MAINTENANCE INSTRUCTIONS.....	26
CHANGES AND MODIFICATIONS.....	27-28
PARTS LIST.....	29-32
OBSOLETE FREEZERS.....	33-34

SPECIFICATIONS

SCOTSMAN SF-2 Super Flaker is designed for restaurants, super markets, bakeries, dairies, fish markets, hospitals, cafeterias, poultry stores, soda fountains, etc. and will deliver a continuous flow of ice flakes at a capacity up to 650 lbs. per day.

ATTRACTIVE COMPACT CABINET. Silver grey hammerloid finish with chrome trim, rounded corners, and removable panels for easy access to mechanical parts.

SEALED REFRIGERATION SYSTEM. Provides quiet, efficient operation of the machine. Compressor motor is spring mounted and the worm motor is rubber mounted for quiet operation.

HOW IT WORKS. Water in the constant level float reservoir is fed to the bottom end of a freezing cylinder and turns to ice on the inside of this cylinder. The stainless steel auger inside of this evaporator is driven by a motor through a V belt and gear reduction drive. Ice is carried upward by the action of this auger and extruded past the ice breaker at the top of the cylinder.

A manual switch starts the machine, and from then on ice is produced automatically in small uniform pieces of ice. When the storage bin fills, a thermostat shuts the machine off and causes it to start up again when ice is taken from the storage compartment.

SF-2F CONTINUOUS FLOW

INSTALLATION DIMENSIONS

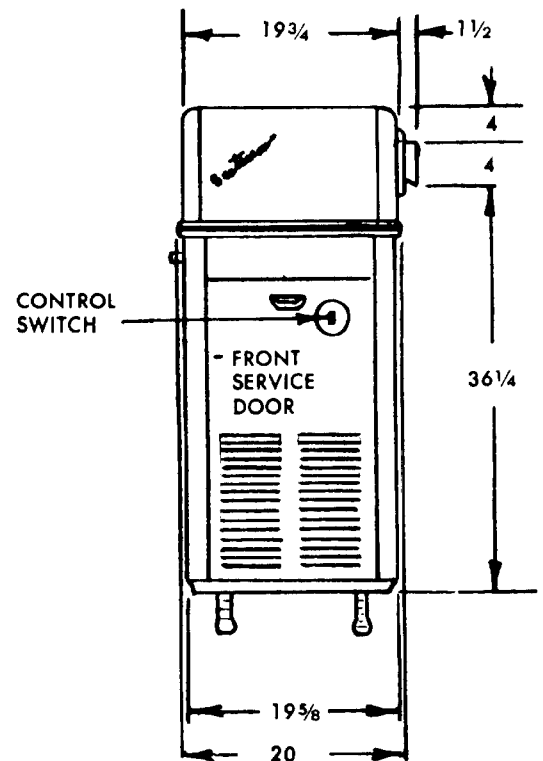
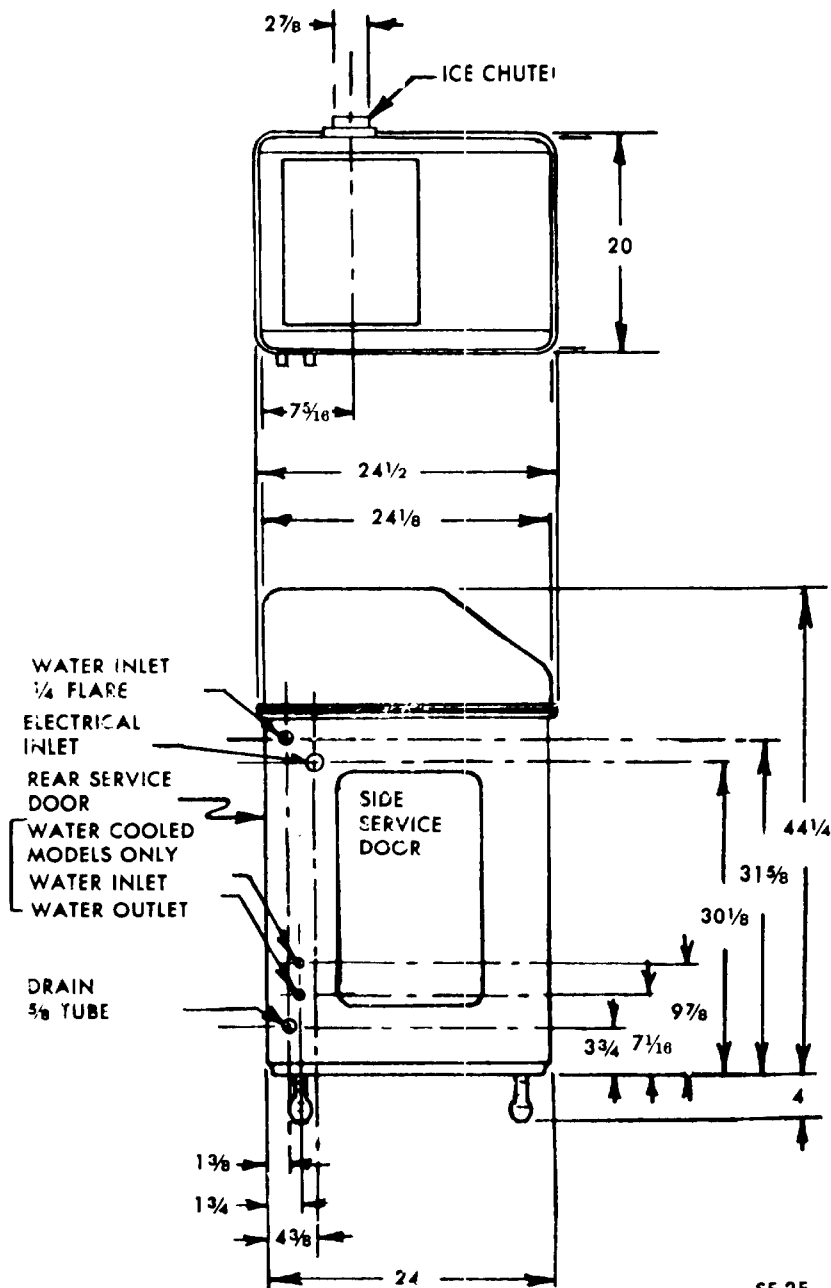
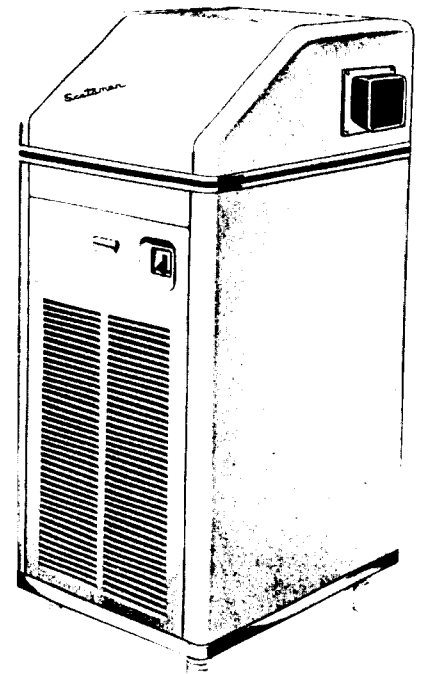

SF-2F

SF-2WSF AUTOMATIC STORAGE

INSTALLATION DIMENSIONS

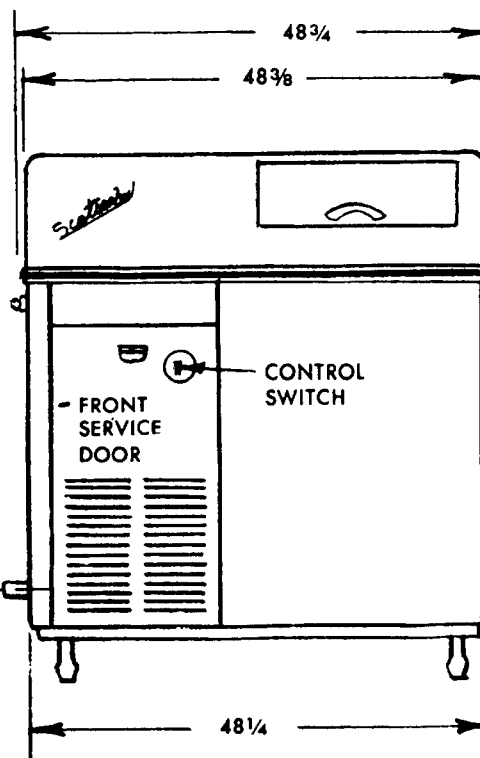
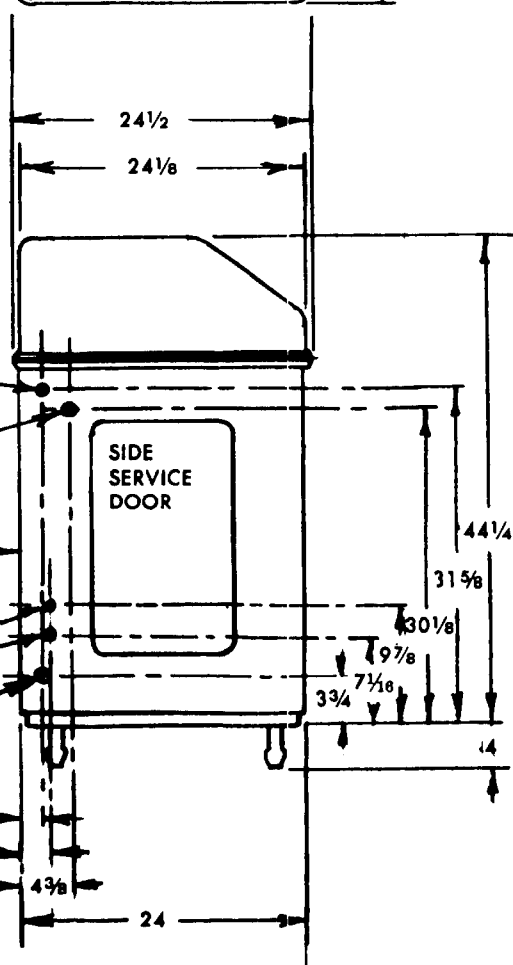
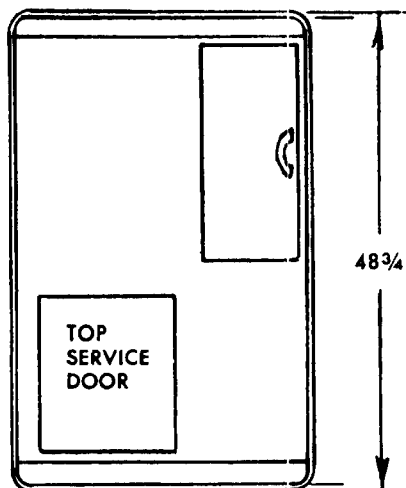
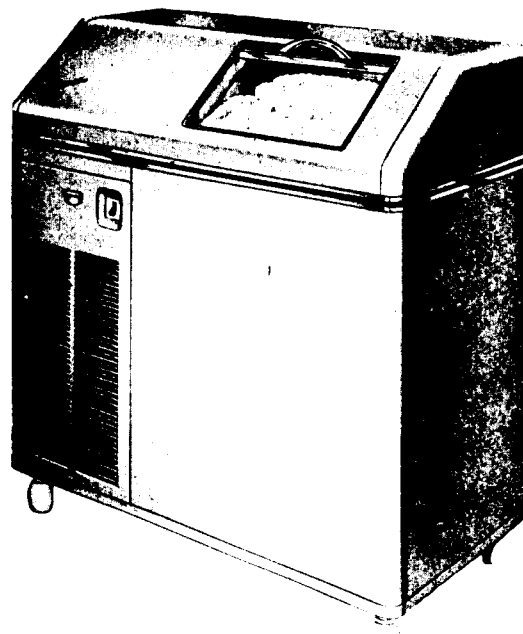

SF2-WSF

ICE MAKING CAPACITY
SF-2F Super Flakers
130 PSI Condensing
on Water Cooled Models

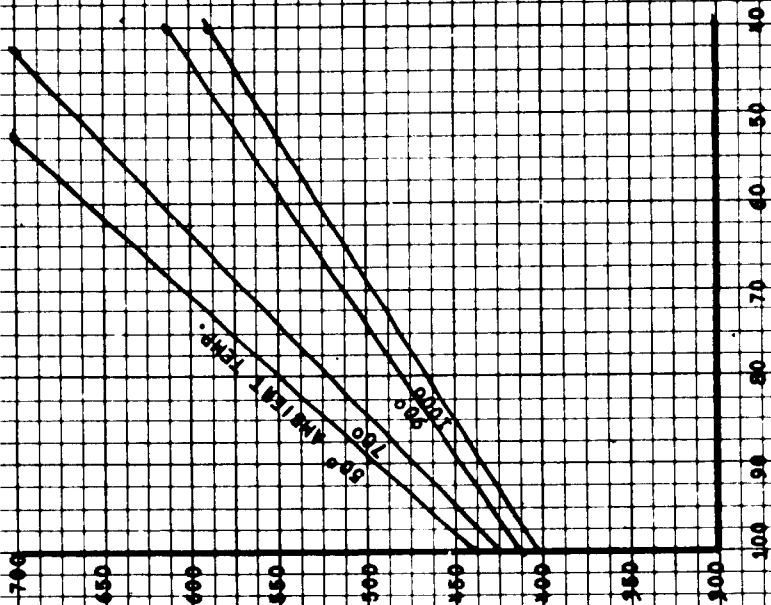

SF-2MF
Water Cooled

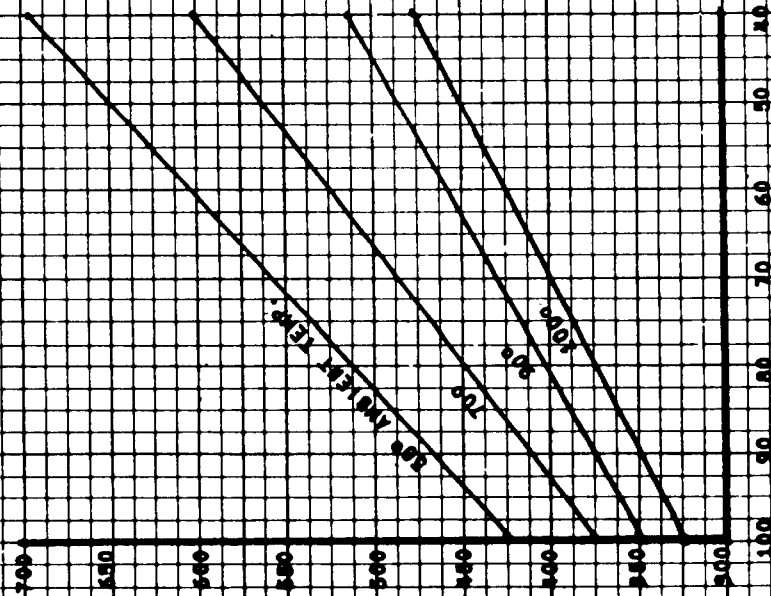

SF-2F
Air Cooled

INSTALLATION

UNCRATING OF MACHINE

The complete machine comes in one crate. After the crate is removed, inspect for concealed damage. When installing the machine, remove the bottom skids by removing all bolts. Then cut all wires holding support packing from refrigerant lines. Then loosen shipping bolts on the compressor. Be sure the compressor is floating free on spring mounts. Remove leg levelers from the carton and install on base as desired. Then check all refrigerant lines for rubbing or touching other surfaces. Also check for possible transportation damage. Check for free movement of ice worm.

PRE-INSTALLATION CLEANING

Before machine is in final location, remove warranty card and other information from machine compartment. Remove top service door, water reservoir cover and packing under float. Then leave cover off for float adjustment after machine is installed.

LOCATION OF THE SUPER FLAKER

Select the location before delivering Super Flaker to the job. The following points should be considered when making selection.

1. Convenience. Place the unit as close as possible to the place of ice consumption.
2. Servicing. Install the machine on continuous flow models so it can be serviced from all three sides except the side containing the ice chute opening. Important to leave 24" access to front (containing on-off switch) and left side on both with storage and continuous flow models.
3. Room Temperature. Minimum - 50 degrees. Maximum - 100 degrees.
4. Continuous Flow Models.
 - A. Bins. Care should be exercised in proper bin selection. Too small a bin will give unsatisfactory performance. A bin should have a minimum of 1/2 of machine's capacity per day, when the machine shuts off on thermostat. Make

INSTALLATION

sure that user's demands are met by proper bin as well as by proper machine selection. Plan relative location of the machine so as to enter the bin as close to the top as possible. Bins should also be higher than their width and length dimensions, so the maximum ice can be stored in the minimum cubic feet of space. A Scotsman bin is designed in this fashion and will be the most convenient to the user. Too large a bin can cause trouble. Excessive melting of ice will occur if the bin is larger than required. Proper bin selection is important to the success of the ice machine installation.

- B. Stands. A Scotsman Machine stand should be used if the machine is located beside the Scotsman bin. In designing the installation, plan for servicing of the machine from front, top, and sides.
- C. Erection. For elevations in excess of four feet or in close quarters, chain falls should be used. For locations under four feet, the use of skid boards and rollers are practical.
- D. Bin Thermostat. Locate the thermostat bulb as high as possible in the bin and still allow the machine to cut off before ice builds up in the chute. If this occurs, ice can stick in the chute keeping the machine off after there is a need for ice production. The capillary can usually enter through the chute opening. Keep the bulb and capillary line away from shovels.
- E. Ice Chutes. If the outlet of the machine is remote from the bin, a chute will be required. Stainless steel is an excellent material for this purpose where its' cost is not prohibitive. Angles or ledges of less than 45° should not be used. Ice will cling to this surface and either melt excessively or jam in the chute. The sharper the drop the better. If straight down, do not insulate, unless necessary.

**THERE IS NO DOCUMENT
FOR THESE NUMBERS**

Page 7 thru Page 14

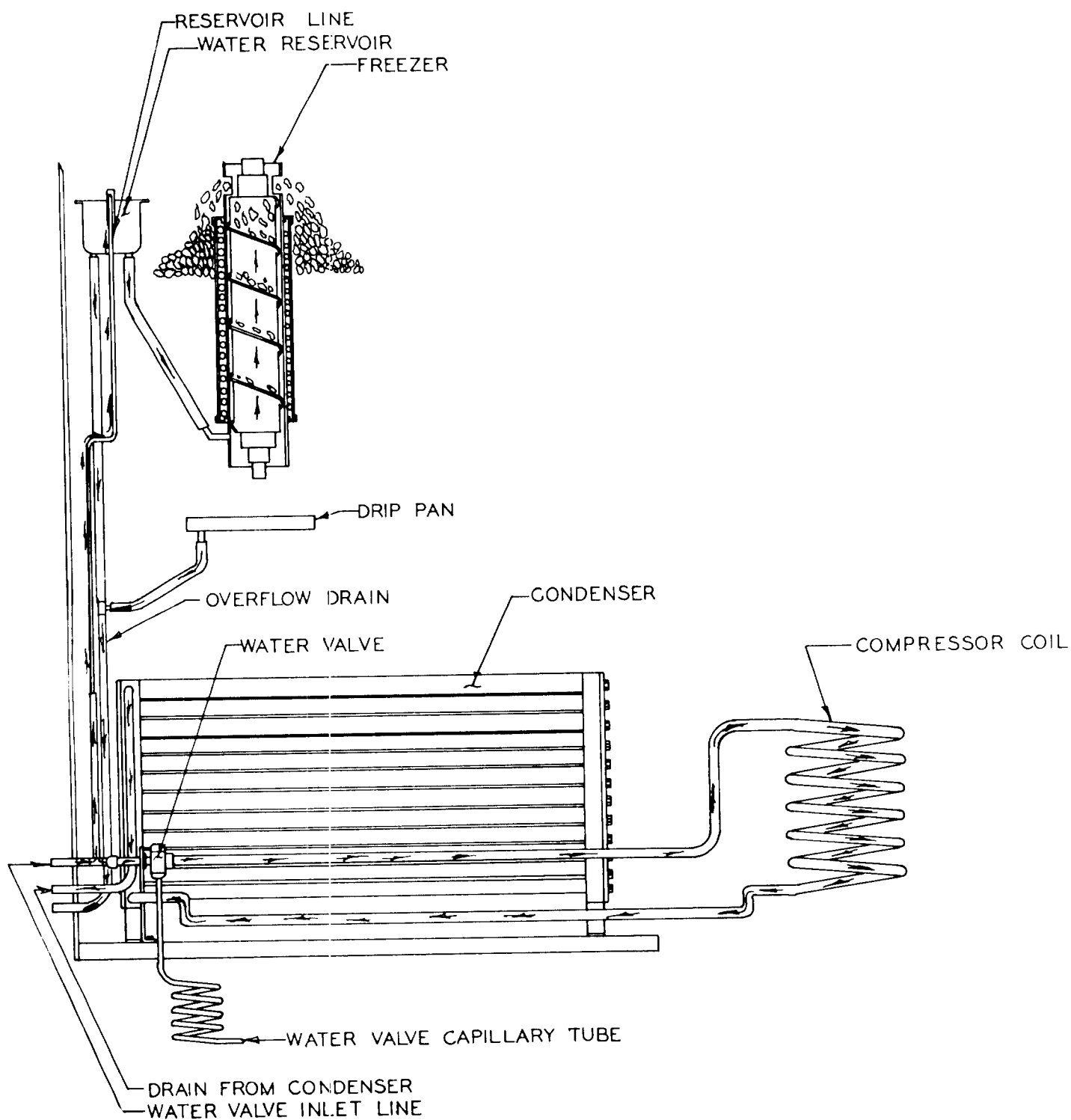

WATER COOLED MODELS

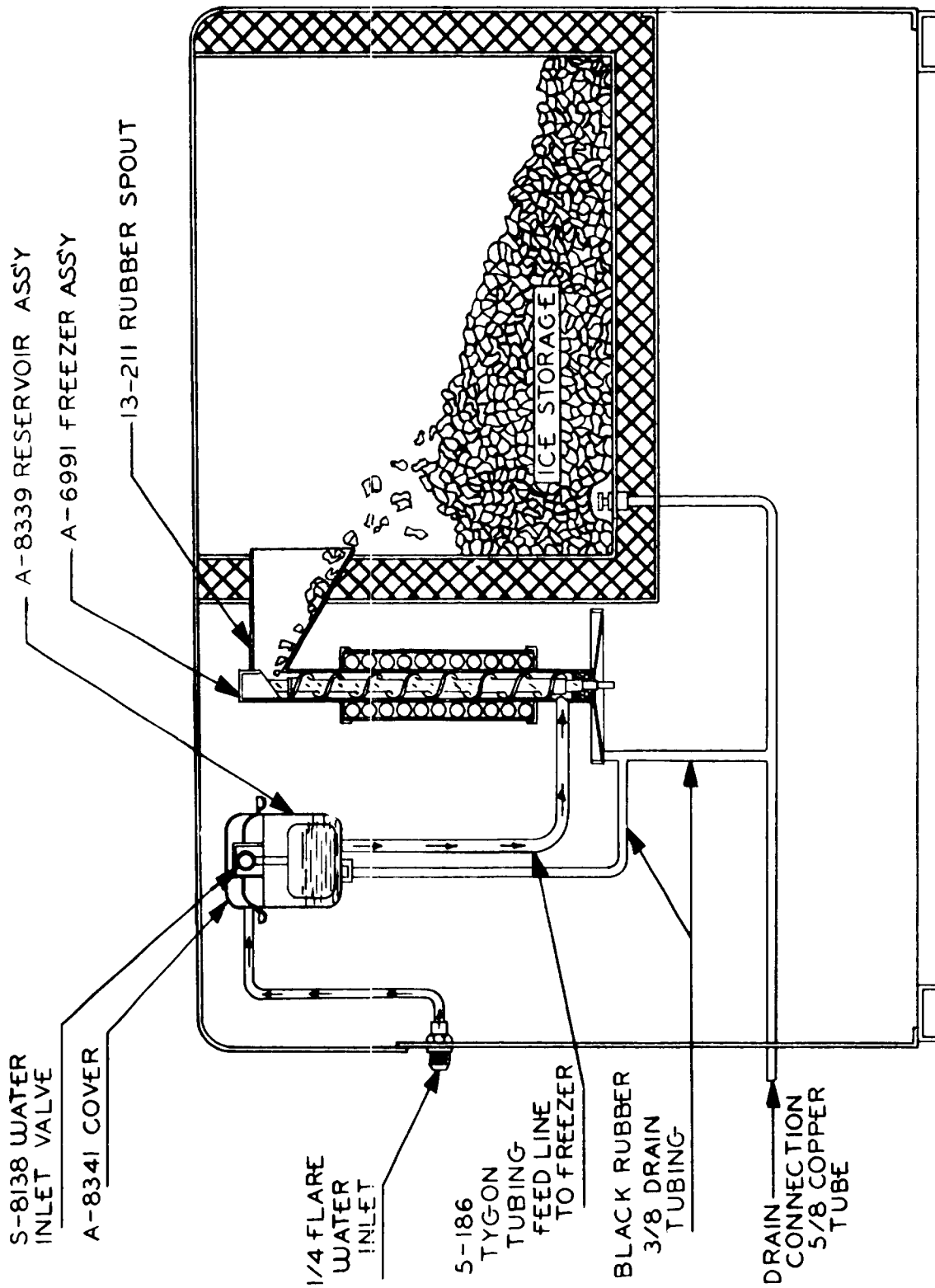

WATER SCHEMATIC
SF-2WSF

A-8344 SPOUT INSULATION
A-8345 SPOUT INSULATION

A-8144 COMPLETE RESERVOIR ASSY
A-8341 RESERVOIR COVER ASSY
A-8339 WATER RESERVOIR ASSY

13-211 RUBBER SPOUT
A-8612 SPOUT CLAMP
A-8065 MICRO COVER
3-473 SCREW

11-273 LO-PRESSURE CONTROL
12-474 RESISTOR
11-264 HI-PRESSURE CONTROL
A-8357 JUNCTION BOX COVER ASSY
11-99 TEMP CONTROL

A-8074 FEEDER TUBE
2-694 CLAMP
2-535 CLAMP
13-165 V BELT
13-152 RUBBER SHIELD
2-378 PULLEY

3-517 SCREW(2)

A6991 FREEZER ASSY
A-6165 COUPLING
13-131 INSERT
S-7716 COUPLING
2-337 REDUCER

S-7579 COMPRESSOR BOX COVER

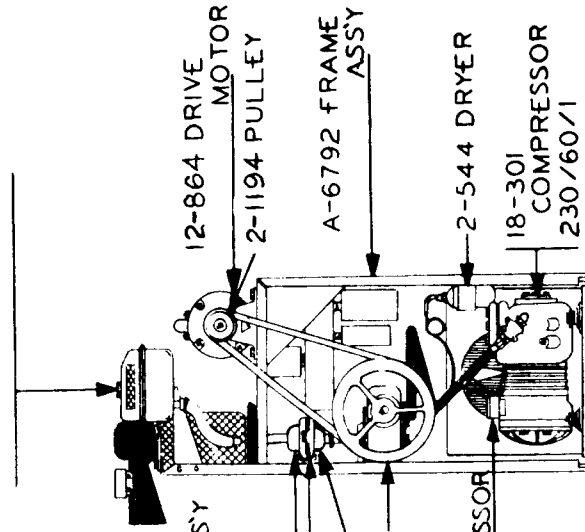

CHASSIS ASSEMBLY
AIR COOLED
SF-2F

SF-2F FREEZER ASSEMBLY

PART NO. A-6991

A change was made in the water seal and the bottom bearing retainer as is noted in the cut-away view.

This change went into effect starting with SF-2F, Serial No. 99-007484, and SF-2WSF, Serial No. 99-007629—SF-3F, Serial No. 910-006709 and SF-3WSF, Serial No. 910-006888.

In Mail Order stock, we still carry part no. 2-648 water seal as a replacement part, however, we do not carry any more A-6152 bearing retainers. New bearing retainer part no. A-10591, which is shorter in overall height must be used. It also then means that the new style part no. 2-929 water seal is required; this would apply to all the past freezers using the A-6152 retainer.

These parts are interchangeable insofar as they fit into all the old style SF-2F freezers as noted.

All mail order replacement freezers will also incorporate this change.

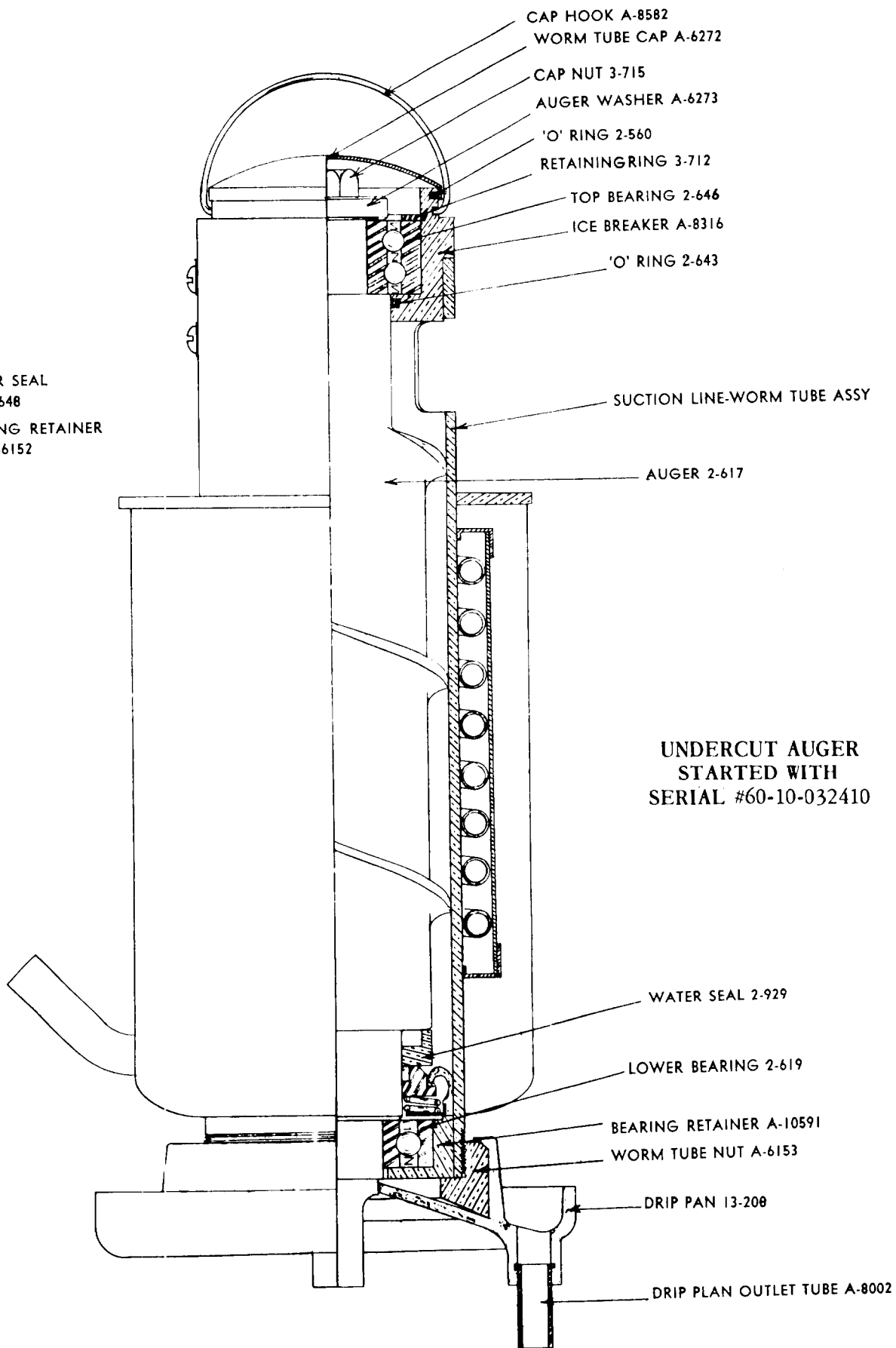

NOTE:
OBSOLETE WATER SEAL
WAS PART No. 2-648
OBSOLETE BEARING RETAINER
WAS PART No. A-6152

UNDERCUT AUGER
STARTED WITH
SERIAL #60-10-032410

FREEZER ASSEMBLY

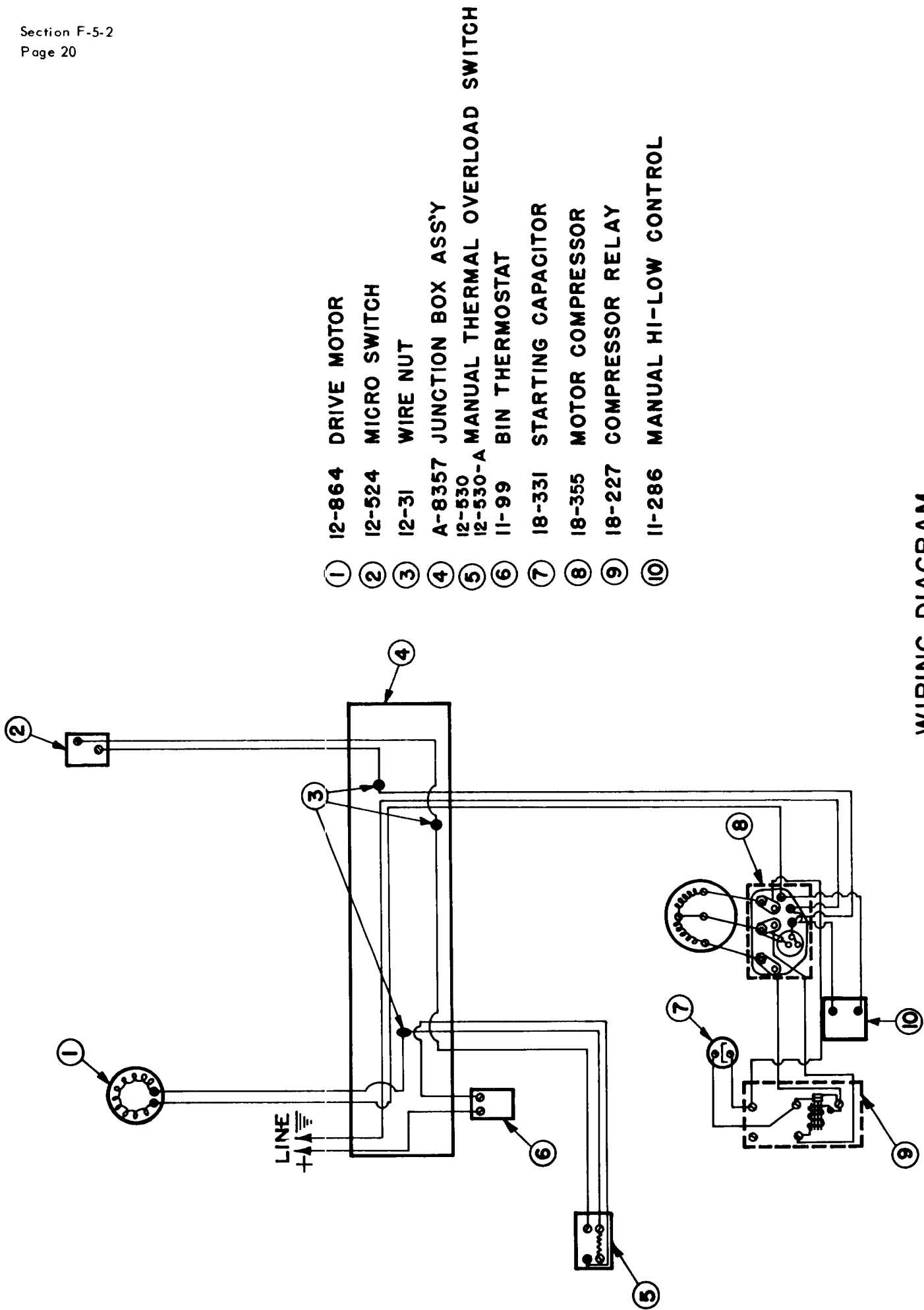

- ① 12-864 DRIVE MOTOR
- ② 12-524 MICRO SWITCH
- ③ 12-31 WIRE NUT
- ④ A-8357 JUNCTION BOX ASS'Y
- ⑤ 12-530 MANUAL THERMAL OVERLOAD SWITCH
- ⑥ 12-530-A
- ⑦ 11-99 BIN THERMOSTAT
- ⑧ 18-331 STARTING CAPACITOR
- ⑨ 18-355 MOTOR COMPRESSOR
- ⑩ 18-227 COMPRESSOR RELAY
- ⑪ 11-286 MANUAL HI-LOW CONTROL

WIRING DIAGRAM
WATER COOLED SF-2F
H5/60/1

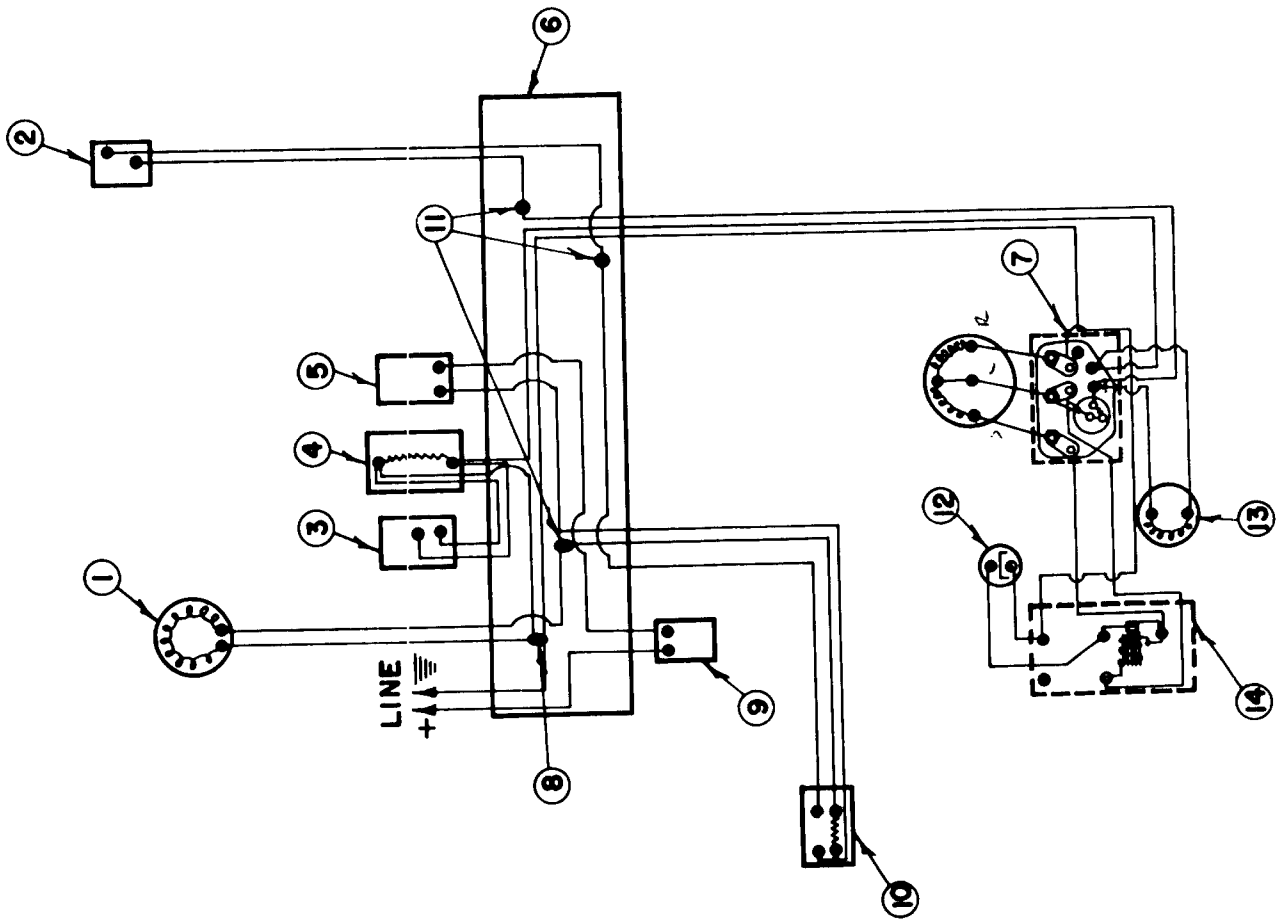

- ① 12-864 DRIVE MOTOR
- ② 12-524 MICRO SWITCH
- ③ 11-264 HI PRESSURE CONTROL
- ④ 12-474 RESISTOR 175 OHM
- ⑤ A-7221 RESISTOR BOX
- ⑥ 11-273 LO PRESSURE CONTROL HAND RESET
- ⑦ A-8356 JUNCTION BOX ASS'Y
- ⑧ 18-325 MOTOR COMPRESSOR
- ⑨ 12-184 WIRE NUT
- ⑩ 11-99 BIN THERMOSTAT
- ⑪ 12-530 MANUAL THERMAL OVERLOAD SWITCH
- ⑫ 12-31 WIRE NUT
- ⑬ 18-331 STARTING CAPACITOR
- ⑭ 18-333 CONDENSER FAN MOTOR
- ⑮ 18-227 COMPRESSOR RELAY

WIRING DIAGRAM
AIR COOLED SF-2F
115/60/1

SERVICE ANALYSIS CHART

COMPLAINT	POSSIBLE CAUSE	CORRECTION
<p>Low ice production.</p>	<p>Loss of refrigerant. Under or over-charge of refrigerant.</p> <p>Drive motor weak.</p> <p>Dirty or plugged condenser.</p> <p>Low water level in water reservoir.</p> <p>Overcharge of oil in system.</p> <p>Partial restriction in capillary tube or drier.</p> <p>Inlet water strainer partially plugged.</p> <p>Corroded or strained worm shaft due to water condition.</p> <p>Slipping drive belt.</p> <p>Defective gear reducer.</p>	<p>Check and recharge with proper amount of refrigerant.</p> <p>Replace.</p> <p>Clean condenser.</p> <p>Adjust to 1/4 inch below spout opening.</p> <p>Check at oil hole and lower to 1 1/2 inch from top of hole or 1/3 full on crankcase sight glass.</p> <p>Moisture in system. Over-charge of oil in system. Remove charge by blowing back through cap tube. Replace and recharge.</p> <p>Remove screen and clean.</p> <p>Remove worm shaft and clean, or use Scotsman Ice Machine Cleaner. See Maintenance Section.</p> <p>Adjust belt tension or replace worn belt.</p> <p>Check reducer driven shaft to freezer shaft. Should rotate at 12 R P M. Replace if worn.</p>
<p>Machine runs but makes no ice.</p>	<p>Loss or undercharge of refrigerant.</p> <p>Drive motor, belts, gear reducer on drive coupling inoperative.</p> <p>Pulleys loose on shafts.</p>	<p>Check for leaks and recharge.</p> <p>Gear reducer and worm turn at 12 R P M. Check. Repair or replace.</p> <p>Tighten, repair or replace.</p>

SERVICE ANALYSIS CHART

COMPLAINT	POSSIBLE CAUSE	CORRECTION
Machine runs but makes no ice. (Cont.)	<p>Water not entering freezing chamber.</p> <p>Moisture in system.</p> <p>Water seal leaking.</p> <p>Defective manual overload switch.</p>	<p>Plugged strainer or supply line. Check and clean. Air lock in gravity feed line. Check and remove air lock.</p> <p>Check and remove charge and drier. Replace and recharge.</p> <p>Replace seal. See section on maintenance.</p> <p>Replace switch.</p>
Water leaks.	<p>Defective water seal.</p> <p>Gravity feed line leaking.</p> <p>'O' ring in spout casting leaking.</p> <p>Storage bin drain and connecting fittings.</p> <p>Water level in reservoir too high.</p>	<p>Replace. See section on maintenance.</p> <p>Check hose clamps.</p> <p>Remove spout casting and install new 'O' ring.</p> <p>Check and repair. Tighten fitting - replace 'O' ring.</p> <p>Adjust to 1/4 inch below overflow pipe.</p>
Excessive noise or chattering.	<p>Scale or mineral build-up on inside of freezer.</p> <p>Mineral deposit or scale on auger and cylinder walls.</p> <p>Low suction pressure.</p> <p>Intermittent water supply.</p> <p>Water level in reservoir too low.</p> <p>Mis-aligned coupling or worn insert.</p>	<p>Clean with Scotsman Ice Machine Cleaner. See section on maintenance.</p> <p>Ice sticking and jamming inside. Clean with Ice Machine Cleaner or remove auger and polish.</p> <p>Raise suction pressure. Adjust head pressure control to recommended setting or balance refrigerant charge.</p> <p>Check and clean water strainer. Check gravity feed line for air lock. Remove air lock.</p> <p>Adjust to 1/4 inch below overflow pipe, or raise reservoir.</p> <p>Repair or replace.</p>

SERVICE ANALYSIS CHART

COMPLAINT	POSSIBLE CAUSE	CORRECTION
<p>Excessive noise or chattering. (Cont.)</p>	<p>Low ambient temperature.</p> <p>Gear reducer low on oil charge.</p> <p>Gear reducer loose on frame.</p> <p>Pulleys worn or loose on shaft.</p> <p>Belt cracked or worn.</p> <p>Drive motor end-play or worn bearings.</p> <p>Motor compressor not floating on springs.</p>	<p>Set head pressure and resultant back pressure higher, or move to heated space.</p> <p>Check oil level and refill to oil level plug.</p> <p>Tighten.</p> <p>Repair or replace.</p> <p>Replace belt.</p> <p>Repair or replace.</p> <p>Loosen hold-down bolts.</p>
<p>Machine continues to run with full storage bin.</p>	<p>Storage bin thermostat not properly set or is defective.</p>	<p>Reset or replace. 35° cut-out, 45° cut-in.</p>

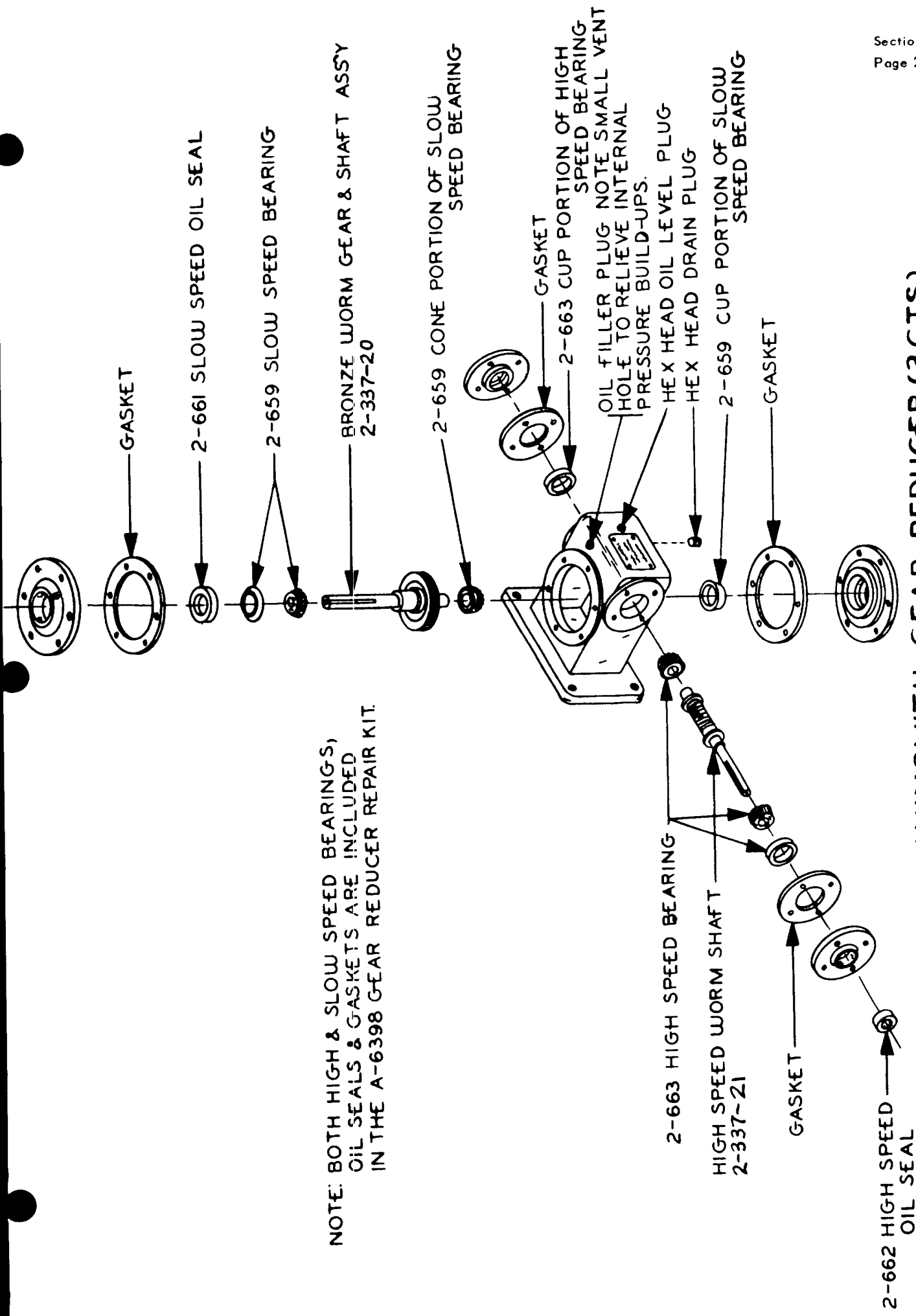

NOTE: BOTH HIGH & SLOW SPEED BEARINGS, OIL SEALS & GASKETS ARE INCLUDED IN THE A-6398 GEAR REDUCER REPAIR KIT.

WAINSMITH GEAR REDUCER (3CTS)
QUEEN PART NO. 2-337
USED ON ALL MODELS SF-2F & SF-2WSF

MAINTENANCE INSTRUCTIONS
FOR
SCOTSMAN SUPER FLAKERS

The following services must be accomplished a minimum of two (2) times per year on all Scotsman Super Flakers.

1. Check and clean water strainers and float valves. Depress float valve to insure full stream of water.
 2. Check water level and machine level. Keep water level below overflow but as high as possible and still not run out of spout opening with machine off. Water should come out of spout with ice at all times. Adjust as required.
 3. Clean reservoir and interior of freezer assembly using Scotsman Ice Machine Cleaner.
 - A. If machine has been cleaned regularly and no problems such as dry ice or chatter are noticed, clean by making ice from solution of 8 oz. of cleaner to one gallon of water.
 - B. If heavy mineral deposits on auger and walls, or sediment at inlet to freezer are encountered, clean by pouring strong solution (1/2 acid - 1/2 water) into reservoir and operate drive motor only for agitation. Allow 1/2 hour or longer as required. Drain by disconnecting tygon at water inlet to freezer.
- Note: Cleaning requirements vary according to local water conditions. Visual inspection of the auger before and after cleaning will indicate best procedure to be followed in local areas.
4. Check high and low side pressures. On air cooled models set head pressure between 130 and 145 PSI on R.A. high pressure control. On water cooled models, set pressure at 130 PSI. Suction pressure should be above 12 PSI and will range upto 16 PSI depending upon ambient and water temperatures.
 5. Set hand reset low pressure control to cut off in event of water supply interruption or low ambient temperature at approximately 5 PSI.
 6. Change oil in gear reducer. Use 600W or grease with BRB No. 1 or equivalent when grease fittings are evident. Particularly important when there is evidence that water has gotten into gear housing. Remove gear reducer to facilitate.
 7. Oil drive motor. Use SAE 20 oil.
 8. Check top bearing of freezing tube. Pry upward around edge of stamped brass cap. If moisture is around bearing, wipe up and remove grease. Add new grease Use lubriplate No. 5. To replace cap, insert small wire under cap edge to vent air and remove when cap is on tight.
 9. Check and adjust belt tension.
 10. Clean air cooled condenser. Inform customer to clean frequently. Always shut off machine when cleaning.
 11. Oil condenser fan motor when possible.
 12. Check for refrigerant leaks and proper frost line. Should frost out of accumulator approximately two feet.

MAINTENANCE INSTRUCTIONS
FOR
SCOTSMAN SUPER FLAKERS

13. Check for water leaks. Tighten drain line connections. Run water down bin drain line to make sure it is open.
14. Check quality of ice. Ice should be wet when formed but will cure rapidly to normal hardness in the bin.
15. Check thermostat and pressure plate cut off. Micro-switch cuts off only compressor. Bin thermostat should be set at 10° differential and should keep entire machine off at least twenty minutes in high ambients (longer in low) during normal operation. Set cut out at 35°, cut in at 45°.

CHANGES AND MODIFICATIONS

Drive Motor is 1/4 Horsepower 115/60/1

CURRENT	OBSOLETE
Part Number - 12-864-1	12-712-1
Nema Frame Size - 48	56
Shaft Diameter - 1/2"	5/8"
Pulley to Shaft - 2-1194	2-388
Pulley Attachment to Shaft Set Screw on Flat	Keyway and Set Screw

The mounting brackets of the two motors are not interchangeable. On units with serial numbers lower than 52-2 prefix; order old style 56 frame motors. On newer units order only 48 frame motors.

CHANGES AND MODIFICATIONS

INLET VALVES

On all water inlet valves S-6941, S-8138, A-6771 and A-9101 we have incorporated a new type of float assembly. On past assemblies, the float ball was screwed onto an arm and adjusted by means of a set screw and tension spring. The new type float assembly is a one-piece affair that can be adjusted by merely bending the arm up or down. On this new type float assembly the arm and float will be available as a complete unit only. This will consist of the float ball, float arm, valve seat holder and rubber valve seat. The respective new type float assemblies are interchangeable on all water inlet valves used in the past.

On the old style water inlet valves where the float ball was screwed onto the arm, the float ball itself will continue to be carried as a field replacement part. However, when the present supply of water inlet valves using the old style float arms have been exhausted, the valves will all be equipped with the new type float arm assembly.

The basic part of the valve will not change and will continue to be carried under the same part numbers as in the past. The following list will outline the respective valves and replacement arm assemblies:

S-6941 - Water Inlet Valve Complete - All Early Model Flakers & Cubers
(Has short float arm.)

- A. A-12511 Complete Float Arm Assembly
- B. 2-463 Float Ball only - For old style float arm.

S-8138 - Water Inlet Valve Complete - All Current Model Flakers
(DF-4, SF-75, SF-1, SF-2, SF-3)

- A. A-12509 Complete Float Arm Assembly
- B. 2-463 Float Ball only - For old style float arm.

S-6237 - SLIDING DOOR

The sliding door used on all models, both flakers and cubers with storage, will now have a different arrangement for the hinge pin assembly. The hinge pins S-6019 and hinge pin holder S-6019 will no longer be used on the new door arrangement. Replacing the hinge pins and hinge pin holders will be a one piece brass rod A-11696 running completely through door and secured with two (2) cotter pins 3-196-1.

The new door assembly will still be carried under part no. S-6237, and is exactly interchangeable on all past with storage models. We will still carry the hinge pins and hinge pin holders in Mail Order stock for use on those doors presently equipped with same.

PARTS LIST

SF-2F

CABINET PARTS	SF-2F	SF-2WSF
Description	Part No.	Part No.
Case Assembly (Less Doors)	A-9763	A-9764
Case Hood Assembly	A-7176	S-9992
Door Slide Assembly	None	S-7710
Sliding Door Assembly	None	S-6237
Hinge Pin	None	A-11696
Door Handle	None	15-247
Left Side Door Assembly	S-6713	S-6713
Rear Door Assembly	A-8741	A-8741
Front Door Assembly	A-6998	A-6998
Top Door Assembly (Hood Side)	A-6530	A-6530
Top Door Assembly (Over Reservoir)	A-7676	S-6849
Moulding Strip 85"	S-6211	None
Moulding Strip 101" Front	None	S-6413
Moulding Strip 42" Rear	None	A-5829
Legs (4 in kit)	A-12442-1	A-12442-1
Emblem	S-3188	S-3188
Plywood Crate	1-387	1-343
Base Trim Strips 2/unit	A-8902-2	None
Ice Storage Tank Assembly	None	A-7001
Ice Storage Tank Assembly - Drain Tube	None	S-7045

Note: For above cabinet parts in stainless steel,
add 'S' as a prefix to above part numbers.

WATER CIRCUIT	SF-2F	SF-2WSF
Description	Part No.	Part No.
Water Reservoir Assembly	A-8339	A-8339
Reservoir Body	A-13409	A-13409
Stand Pipe Assembly	S-6715	S-6715
Reservoir Cover	A-8341	S-8341
Inlet Valve & Arm Assembly	S-8138	S-8138
Water Deflector	2-1320	2-1320
Rubber Seat	S-6947	S-6947
Water Valve Bracket	A-12869	A-12869
Float Assembly	A-12509	A-12509
Water Supply Strainer	16-162	16-162

PARTS LIST

SF-2F

WATER CIRCUIT		SF-2F	SF-2WSF
Description		Part No.	Part No.
Ice Storage Tank Drain Assembly		None	A-6825
Drain Assembly Strainer		None	A-6448
'O' Ring		None	2-530
Water-Tygon Tubing			
Reservoir to Freezer			
Per foot		5-179	5-186
Bin Thermal Bulb Bracket		None	S-7312
Rubber Tubing			
Drip Pan Drain Hose, per foot		13-79	13-79
Fittings and Clamps			
Rubber Tubing Clamp		2-538	2-538
Tygon Tubing Clamp (with 5-186 tube)		None	2-535
Tygon Tubing Clamp (with 5-179 tube)		2-538	None
FREEZER ASSEMBLY		SF-2F	SF-2WSF
Description			Part No.
Freezer Assembly			A-6991
Ice Breaker			A-8316
Worm Shaft			2-617
Lock Washer	} Part of Ice Breaker		3-679
Brass Machine Screw			3-732
Freezer Cap			A-8581
Freezer Cap Hook			A-8582
Hex Cap Screw			3-715
Washer - Over Top Bearing			A-6273
Top Bearing			2-646
'O' Ring, Shaft			2-643
'O' Ring, Cap			2-560
Retaining Ring			3-712
Worm Tube, Coil and Housing Assembly			A-6382
Water Seal Assembly			2-929
Bottom Bearing			2-619
Bearing Retainer			A-10591
Worm Tube Nut			A-6153
Drip Pan Assembly - Rubber			13-208
Refrigerant Drier		2-544	2-544
Rubber Spout		13-211	13-211
Spout Clamp		A-8612	A-8612

PARTS LIST

ELECTRICAL COMPONENTS	SF-2F
	SF-2WSF

Description	Part No.
Manual Overload Switch	12-530
Ranco - Manual Re-set Lo Pressure Control	11-273
White Rodgers Bin Thermostat (Replaces 11-211)	11-99
Penn Reverse Acting Head Pressure Control - Used on Air Cooled Models only.	11-264 ✓
Lectrohmn Resistor	12-474

CONDENSING UNITS	SF-2F
	SF-2WSF

Description	Part No.
Complete Condensing Unit - Air Cooled 115/60/1	18-301
Motor Compressor Only 115/60/1	18-325
Valve Plate and Gasket Kit	18-326
Relay	18-227
Starting Capacitor	18-331
Condenser Fan Only	18-363
Condenser Motor Only	18-333
Mounting Bracket, Condenser Fan Motor	18-233
Air Cooled Condenser	18-334
Condenser Shroud	18-335
Klixon Thermal Overload	18-347
Electrical Terminal Assembly, includes three complete terminals & board	18-241
Complete Condensing Unit - Water Cooled 115/60/1 (Formerly 12-387)	18-306
Motor Compressor Only 115/60/1	18-355
Valve Plate and Gasket Kit	18-326
Cylinder Head	18-329
Relay (115/60/1)	18-227
Starting Capacitor (115/60/1)	18-357
1/2 H.P. Water Cooled Condenser	18-368
Water Cooled Condenser Gasket - Plain End	18-262
Water Cooled Condenser Gasket - Manifold End	18-263
Klixon Thermal Overload 115/60/1	18-347
Electrical Terminal Assembly, Includes 3 Complete Terminals & Board	18-241
Compressor to Water Valve Hose Assembly	18-260
Compressor to Condenser Hose Assembly	18-261
Water Regulating Valve - Penn	11-198
Ranco Hi-Lo Dual Pressure Control	11-286

PARTS LIST

DRIVE ASSEMBLY		SF-2F SF-2WSF
Description	Part No.	
Drive Motor - 1/4 H.P. - 115/60/1	12-864-1	
Drive Motor - 1/4 H.P. - 230/60/1	12-864-2	
Pulley - 3-1/4"	2-1194	
Pulley - 10"	2-378	
V Belt	13-165	
Coupling Half Bottom	S-7716	
Coupling Half Top	A-6165	
Inserts (Coupling)	13-131	
Set Screws (Coupling)	3-384	
Cap Screw (Coupling) (2)	3-206	
Clamp (Coupling) (2)	S-8496	
Rubber Shield	13-152	
Gear Reducer	2-337	
Gear Reducer Repair Kit	A-6398	
Slow Speed Bearing (2)	2-659	
High Speed Bearing (2)	2-660	
Slow Speed Oil Seal	2-661	
High Speed Oil Seal	2-662	
High Speed Gasket	2-672	
Slow Speed Gasket	2-673	
Slow Speed Bronze Worm Gear and Shaft	2-337-20	
High Speed Gear and Shaft	2-337-21	
MISCELLANEOUS		
Description	Part No.	
Ice Machine Cleaner - Per Case	19-343-1	
Ice Scoops	2-540	
Paint - touch-up cans	10-153	
Gear Reducer Oil - 600W	19-359	
Upper Bearing Grease - Lubriplate No. 5	19-309	
Transformer - (Step Up or Step Down, 115 to 230)	12-210	

OBSOLETE #1

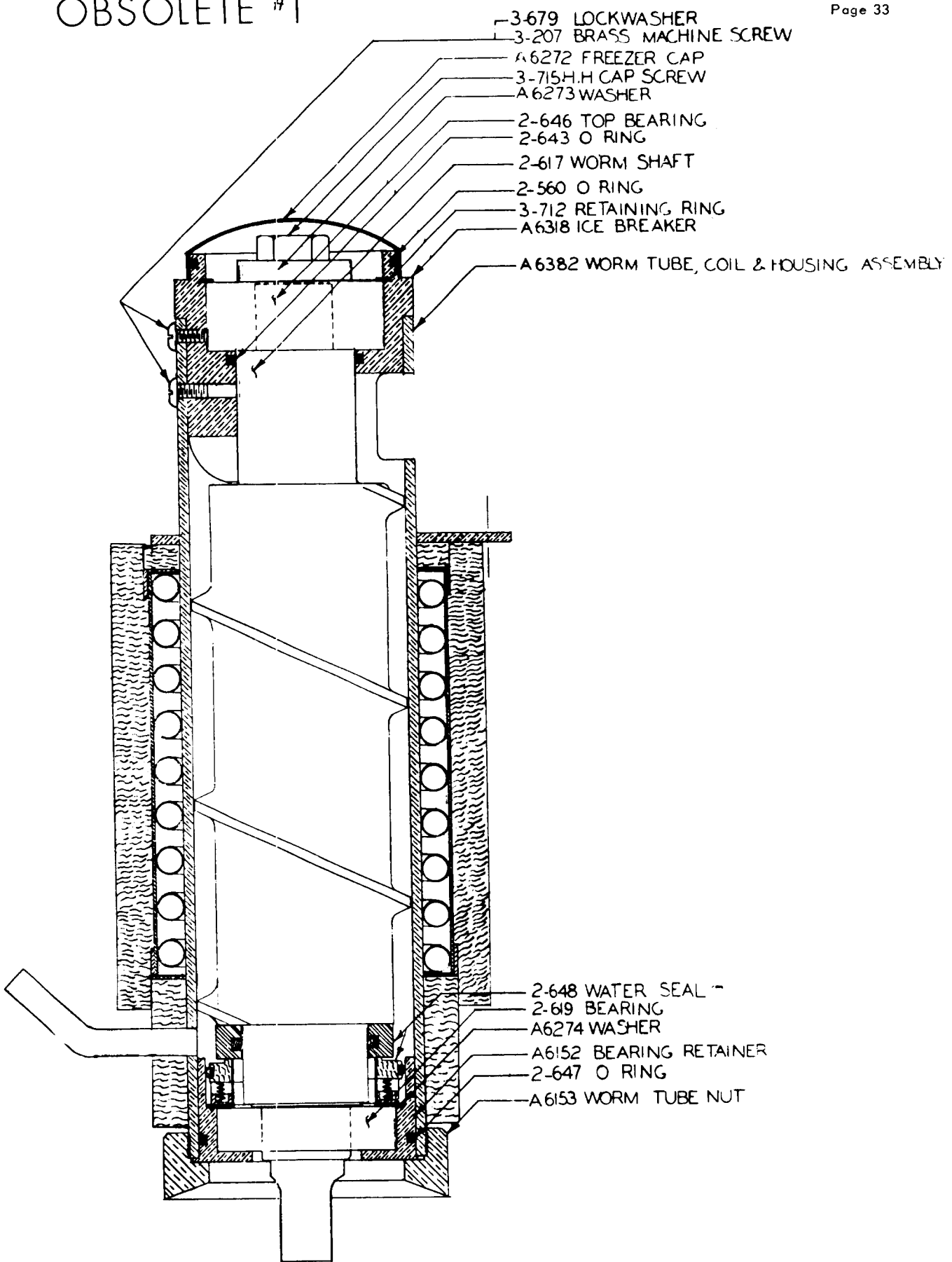









- 3-679 LOCKWASHER
- 3-207 BRASS MACHINE SCREW
- A6272 FREEZER CAP
- 3-715 H.H CAP SCREW
- A6273 WASHER
- 2-646 TOP BEARING
- 2-643 O RING
- 2-617 WORM SHAFT
- 2-560 O RING
- 3-712 RETAINING RING
- A6318 ICE BREAKER
- A6382 WORM TUBE, COIL & HOUSING ASSEMBLY

- 2-648 WATER SEAL
- 2-619 BEARING
- A6274 WASHER
- A6152 BEARING RETAINER
- 2-647 O RING
- A6153 WORM TUBE NUT







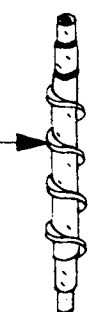

FREEZER ASSEMBLY
SF- 2 F

OBSOLETE #2

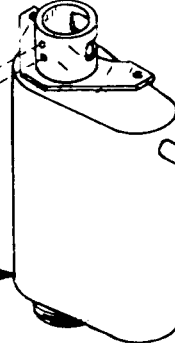
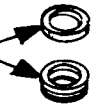
- A-8582 CAP HOOK 
- A-8581 WORM SHAFT CAP 
- 2-560 "O" RING 
- 3-715 LOCKING CAP SCREW 
- A-6273 WORM TUBE WASHER 
- 3-712 RETAINER RING 
- 2-646 TOP BEARING 
- 2-643 "O" RING 
- A-8316 ICE BREAKER 

- 2-617 WORM SHAFT 

USAGE STOPPED
SF2F SERIAL #99-07484
SF2WSF SERIAL #99-07629
CHANGED WATER SEAL
AND RETAINER

- 3-679 LOCKWASHER (2) 
- 3-732 SCREW (2) 
- A-6382 WORM TUBE-SUCTION LINE ASS'Y 
- 2-648 WATER SEAL 
- A-6274 SEAL SPACER 
- 2-619 LOWER BEARING 
- 2-647 O RING 
- A-6152 BEARING RETAINER 
- A-6153 WORM TUBE NUT 
- 13-208 RUBBER DRIP PAN 

FREEZER ASS'Y
SF-2F & SF-2WSF
PART NO. A-6991