

SUBMITTAL Micromet

FORM NO. 12556-1D 4/26/2017

Submitted To:

Company:

Job Name:

Notes:

RGS 180

Part Number:

CRBAP-HE2L-14

Adjustable Pitch Knockdown Curbs

NOTES:

- DO NOT Use A Hard Duct Concentric Package With This Curb.
- * Custom Heights Are Available.
- * Fully Insulated Perimeter Curbs Are Available And Designated With A "CJ" Suffix.
- * Hold Down Brackets Are Available For Most Curbs.
- Attach Ductwork Directly To Roof Curb. Flanges of Duct Rest On Top Of Curb.
- Ductwork Should be 3/4 Inch Smaller Than Duct Openings.
- Any Posted Weight Is Actual Weight, Not Shipping Weight!
- All Dividers & Supports If Present, Are Flush With Top Of Curb Unless Noted.

* Please Contact Factory For Pricing and Availability

FEATURES

- Ships Knockdown, Assembly Hardware Provided When Needed.
- Adjust Up To 1" in 12" Pitch In Either Direction.
- Doubles As An Adjustable Height Curb (Without Pitch)
- Deck pans When Factory Provided are Factory insulated.
- Constructed Of Galvanized Steel.
- Gasketing Package Provided.
- Full Perimeter Wood Nailer Provided.

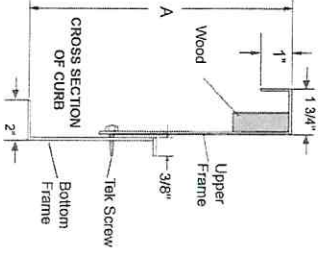
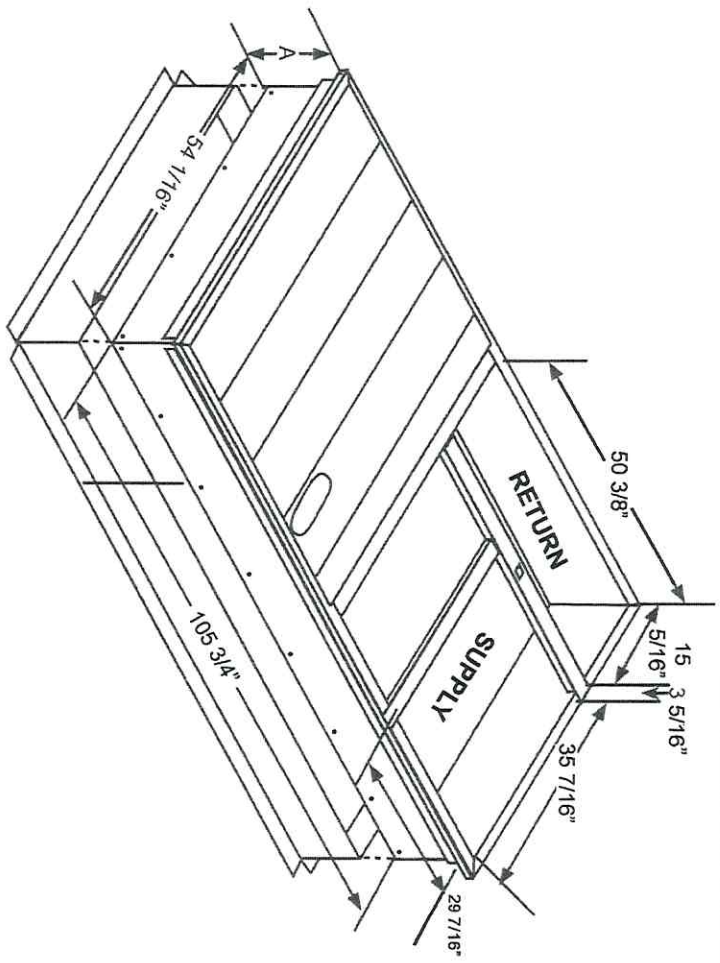

CURB PN	A	Weight
CRBAP-HE2L-14	14"	230 lbs
CRBAP-HE2L-18	18"	258 lbs

CS-20

THIS DOCUMENT IS THE PROPERTY OF MICROMETL CORPORATION AND IS DELIVERED UPON THE EXPRESS CONDITION THAT THE CONTENTS WILL NOT BE DISCLOSED OR USED WITHOUT MICROMETL'S WRITTEN CONSENT

Micrometl Corporation... Indianapolis Indiana — 1-800-662-4822, Sparks Nevada — 1-800-884-4662, Longview Texas — 1-903-248-4800

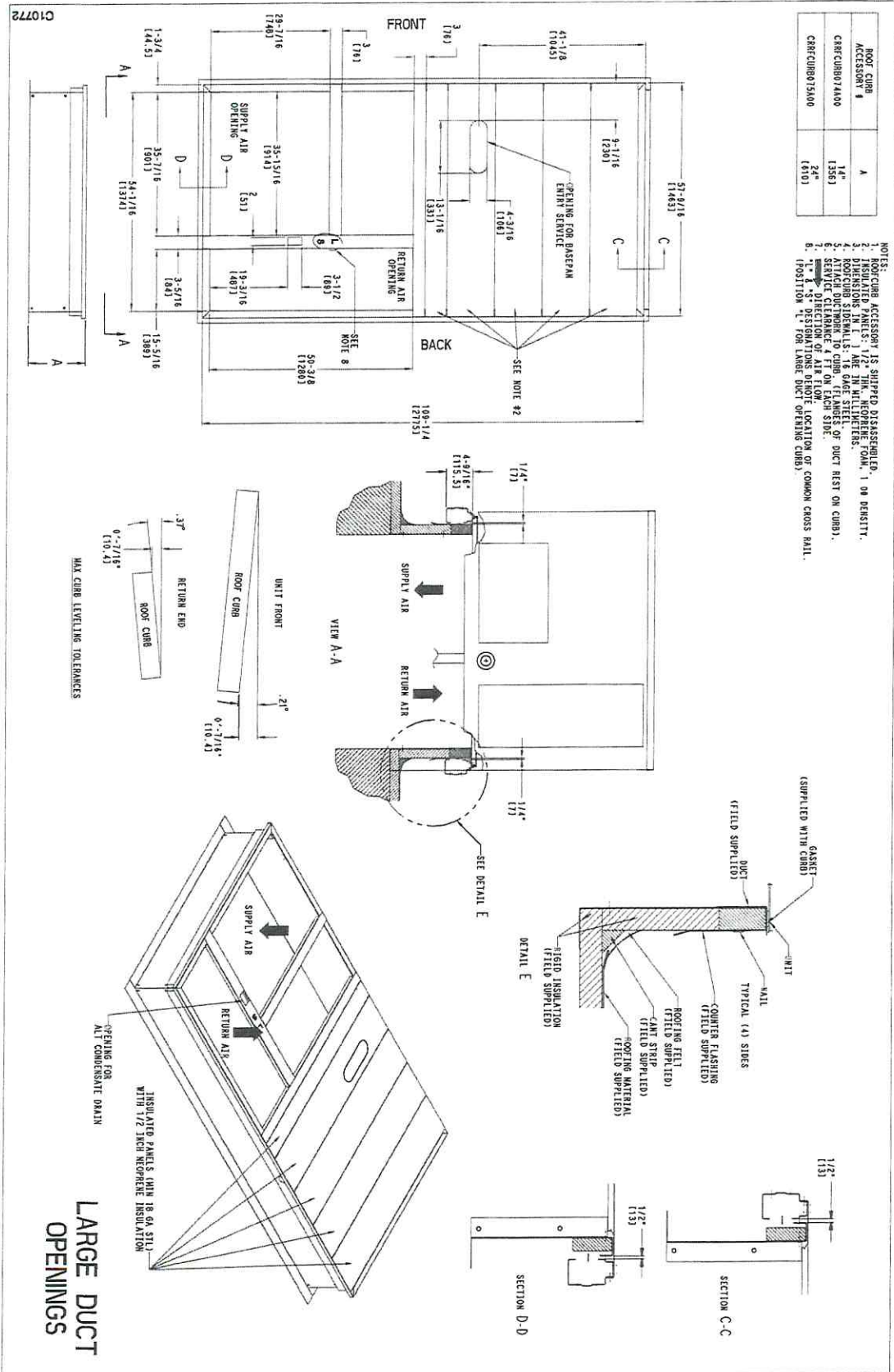

ROOF CURB DETAILS - RGS180

C10772